

---

**TECHNICAL MANUAL**

**OPERATOR'S, ORGANIZATIONAL, DIRECT SUPPORT, AND  
GENERAL SUPPORT MAINTENANCE MANUAL**

**INCLUDING REPAIR PARTS AND SPECIAL TOOLS LIST  
(INCLUDING DEPOT MAINTENANCE REPAIR PARTS AND SPECIAL TOOLS)**

**INTERCOMMUNICATION  
STATIONS**

**LS-626/FSC AND LS-627/FSC**

---

**HEADQUARTERS DEPARTMENT OF THE ARMY  
MARCH 1974**

**WARNING**

**DANGEROUS VOLTAGE**

**DEATH or SERIOUS INJURY** may result from accidental contact with 115 volts ac or -48 volts dc power present in the equipment.

**WARNING**

**TRICHLOROETHANE**

The fumes of trichloroethane used for cleaning purposes are toxic. Provide thorough ventilation whenever used. Do not use near an open flame. Trichloroethane is not flammable, but exposure of the fumes to an open flame converts the fumes to highly toxic, dangerous gases.

Operator's Organizational, Direct Support and General Support  
Manual including Repair Parts and Special Tools List (Including  
Depot Maintenance Repair Parts and Special Tools)

INTERCOMMUNICATION STATIONS LS-626/FSC AND LS-627/FSC

Current as of 18 December 1978

	Paragraph	Page	Figure
CHAPTER 1. INTRODUCTION			
Section I. General	1-1	1-1	
Scope . . . . .		1-1	
Index of publications . . . . .		1-1	
Forms and records . . . . .	1-3	1-1	
Administrative storage . . . . .	1-4	1-1	
II. Description and data			
Purpose and use . . . . .	1-5	1-1	
Technical characteristics . . . . .	1-6	1-1	
Items comprising an operable equipment . . . . .	1-7	1-2	
Description . . . . .	1-8	1-2	
CHAPTER 2. INSTALLATION			
Section I. Service upon receipt of equipment			
Packaging data . . . . .	2-1		
Unpacking instructions . . . . .	2-2	2-1	
Checking unpacked equipment . . . . .	2-3	2-1	
II. Installation instructions			
Tools and test equipment . . . . .	2-4	3-1	
Preinstallation assembling . . . . .	2-5	2-1	
Installation procedures . . . . .	2-6	2-2	
Initial check and adjustment of equipment . . . . .	2-7	2-4	
CHAPTER 3. OPERATION			
Section I. Operator controls and indicators			
General . . . . .	3-1	3-1	
Controls and indicators . . . . .	3-2	3-1	
II. Operation under usual conditions			
General . . . . .	3-3	3-2	
Starting procedure . . . . .	3-4	3-2	
Operating procedure . . . . .	3-5	3-2	
Stopping procedure . . . . .	3-6	3-3	
CHAPTER 4. FUNCTIONING OF EQUIPMENT			
Introduction . . . . .	4-1	4-1	
Intercom system functional block description . . . . .	4-2	4-1	
Central intercom unit circuit analysis . . . . .	4-3	4-1	
Remote intercom unit circuit analysis . . . . .	4-4	4-2	
Amplifier modules . . . . .	4-5	4-3	
5. MAINTENANCE			
Scope of maintenance . . . . .	5-1	5-1	
Tools and test equipment required . . . . .	5-2	5-1	
Preventive maintenance . . . . .	5-3	5-1	
Corrective maintenance . . . . .	5-4	5-2	
Preliminary test procedure . . . . .	5-5	5-2	

	Paragraph	Page	Figure
Operational tests	5-6	5-2	
Troubleshooting procedures	5-7	5-3	
Removal and replacement procedures	5-5	5-5	
Adjustment procedures	5-9	5-5	
<b>CHAPTER 6. SHIPMENT AND LIMITED STORAGE AND DEMOLITION TO PREVENT ENEMY USE</b>			
Repackaging	6-1	6-1	
Authority for demolition	6-2	6-1	
Methods for destruction	6-3	6-1	
Reporting	6-4	6-1	
A. REFERENCES		A-1	
B. BASIC ISSUE ITEMS LIST AND ITEMS TROOP INSTALLED OR AUTHORIZED LIST AND ORGANIZATIONAL, DIRECT SUPPORT, AND GENERAL SUPPORT MAINTENANCE REPAIR PARTS AND SPECIAL TOOLS LIST (INCLUDING SPECIAL TOOLS LISTS (INCLUDING DEPOT MAINTENANCE REPAIR PARTS AND SPECIAL TOOLS)			
Section I.		B-1	
II. Basic issue items list (Not applicable)			
III. Items troop installed or authorized list (Not applicable)			
IV. Organizational maintenance repair parts list (LS-626/FSC).		B-5	1
V. Special tools list (Not applicable)			
VI. Repair parts for direct support, general support and depot maintenance		B-6	
VII. Special tools list (Not applicable)			
VIII. Federal stock number and reference number index (LS-626/FSC).		B-9	
IX. Organizational maintenance repair parts list (LS-627/FSC).		B-11	2
X. Special tools list (Not applicable)			
XI. Repair parts for direct support, general support and depot maintenance		B-12	
XII. Special tools list (Not applicable)			
XIII. Federal stock number and reference number index (LS-627/FSC).		B-15	
<b>APPENDIX C. MAINTENANCE ALLOCATION</b>			
Section I.		C-1	
Maintenance allocation chart.		C-3	

List of Illustrations

Figure	Title	Page
1-1	Intercommunication Stations LS-626/FSC and LS-627/FSC.	1-0
2-1	Central intercom internal view	2-2
2-2	Remote intercom, internal view	2-3
2-3	External wiring of P1 and P2.	2-4
2-4	Typical intercom cross-connect diagram.	2-5
3-1	Central intercom unit controls and indicators.	3-1
3-2	Remote intercom unit, controls and indicators.	3-1
4-1	Central and remote intercom system, functional block diagram	4-1
1	Remote intercom, parts location diagram.	B-15
2	Central, intercom, parts location diagram	B-16
F0-1	Color code markings for resistors, and capacitors.	Fold-in
F0-2	Central intercom unit, schematic diagram	Fold-in
F0-3	Remote intercom unit, schematic diagram	Fold-in
F0-4	TLC-503 preamplifier module schematic diagram	Fold-in
F0-5	TLC-409 power amplifier module, schematic diagram	Fold-in

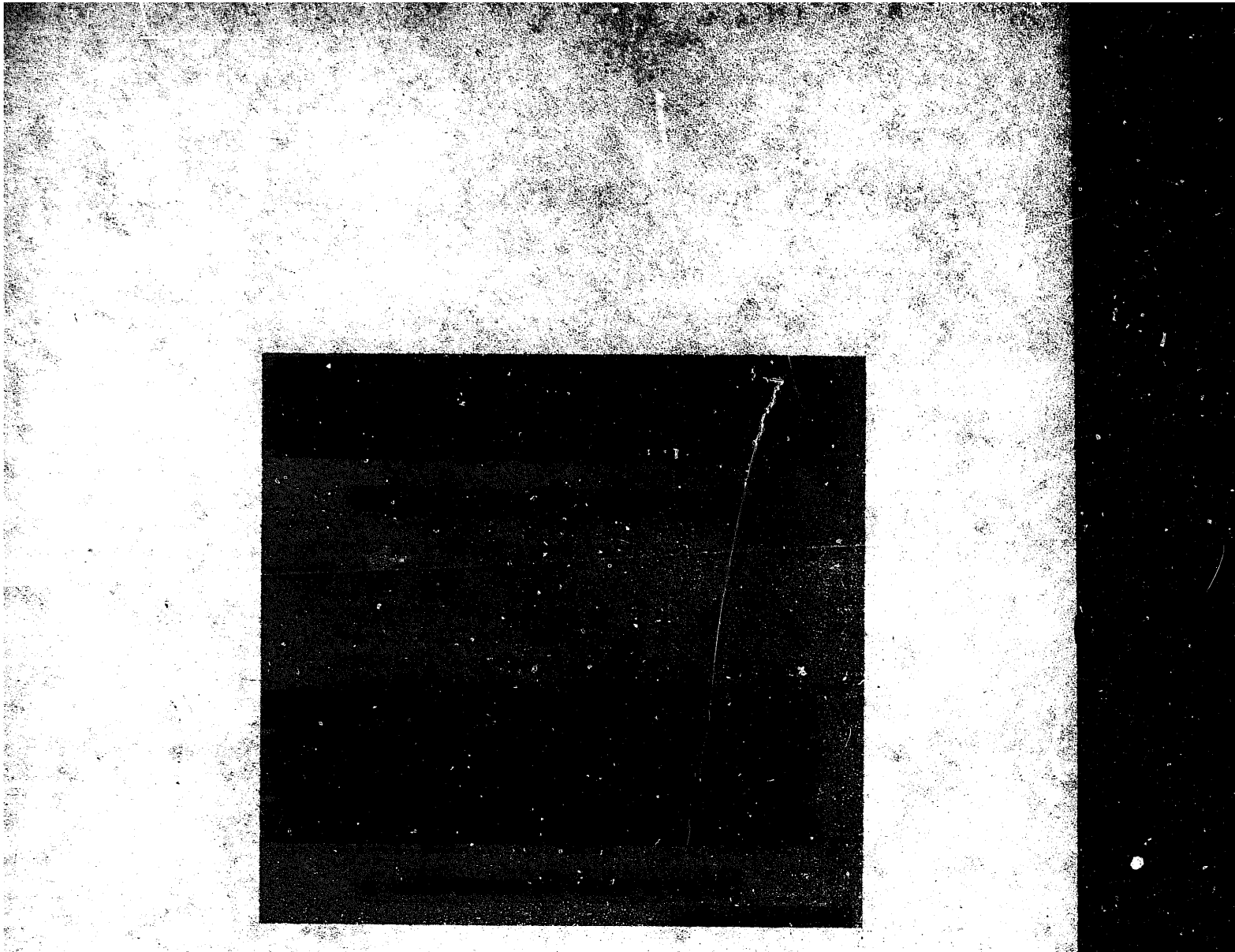

*Figure 1-1. Intercommunication Stations LS-626/FSC and LS-627/FSC.*

## CHAPTER 1

## INTRODUCTION

## Section I. GENERAL

## 1-1. Scope

This manual contains information and instructions for installation, operation, and maintenance of Intercommunication Stations LS-626/FSC (Remote Intercom) and LS-627/FSC (Central Intercom) (fig. 1-1). The maintenance coverage includes all maintenance procedures as authorized by the maintenance allocation chart (MAC) (app C). The components of Intercommunication Stations LS-626/FSC and LS-627/FSC are illustrated in the repair parts and special tools list (app B).

## 1-2. Indexes of Publications

a. *DA Pam 310-4*. Refer to the latest issue of DA PAM 310-4 to determine whether there are new editions, changes or additional publications pertaining to the equipment.

b. *DA Pam 310-7*. Refer to the latest issue of DA Pam 310-7 to determine whether there are new modification work orders (MWO's) pertaining to the equipment.

## 1-3. Forms and Records

a. *Report of Maintenance and Unsatisfactory Equipment*. Use equipment forms and records in accordance with instructions in TM 38-7b0.

b. *Report of Packaging and Handling Deficiencies*. Fill out and forward DD Form 6 (Report of Packaging and Handling Deficiencies) as prescribed in AR 760-58 (Army)/NAVSUP PUB 578 (Navy)/AFR 71-4 (Air Force)/MCS P-4090.29 (Marine Corps), and DSAR 4145.8.

c. *Discrepancy in Shipment Report (DISREP) (SF 361)*. Fill out and forward Discrepancy in Shipment Report (DISREP) (SF 361) as prescribed in AR 55-38 (Army)/NAV-SUPINST 4610.38/AFM 75-18/MCO P4610.19A (Marine Corps), and DSAR 4500.15.

d. *Reporting of Equipment Manual Improvements*. Report of errors, omissions, and recommendations for improving this publication by the individual user is encouraged. Reports should be submitted on DA Form 2028 (Recommended Changes to Publications) and forwarded direct to Commander, US Army Electronics Command, ATTN: AMSEL-MA-CT, Fort Monmouth, NJ 07708.

## 1-4. Administrative Storage

For procedures, forms and records, and inspections required during administrative storage of this equipment, refer to TM 740-90-1.

## Section II. DESCRIPTION AND DATA

## 1-5. Purpose and Use

Intercommunication Stations LS-626/FSC and LS-627/FSC provide voice communication between various equipments, operating positions, maintenance, and command facilities within a communications site. They can be used to implement work in progress, monitor maintenance and operating activities, and supplement communications between points in the facility which are not normally provided with telephone

facilities and are not close enough for direct voice contact.

## 1-6. Technical Characteristics

a. *Intercommunication Station LS-627/FSC.*

- |                                 |                              |
|---------------------------------|------------------------------|
| (1) Power requirements .....    | 48 V dc, 1.5 amperes maximum |
| (2) Number of channels .....    | 20 max.                      |
| (3) Input impedance (listen) .. | 600-ohms                     |
| (4) Output impedance (talk) ..  | 8-ohms                       |

(5) Input level (listen) .....	-6 dBm nominal
(6) Output level (talk) .....	-6 dBm nominal
(7) Mounting requirements .....	Standard 19-inch relay rack
(8) Fuse requirements .....	1-48V, 2 ampere, GBA type
(9) Amplifier data .....	3 used; one Webster TLC-50 microphone preamplifier and two TLC-400 power amplifiers.
(10) Dimensions .....	5 1/4 x 11 1/4 x 19 in.
(11) Weight .....	14 lb.

(12) TLC-500 Microphone Preamplifier data:

Gain .....	0-60 db (adjustable)
Power output .....	0 dBm rated (+15 dBm max)
Frequency response (referred to 1000 Hz) .....	200-3500 Hz ±1.0 dB 100-3000 Hz ±2.0 dB
DC Power required .....	30 ma nominal at 48V dc
Output noise level .....	-50 dBm at 48V dc
Distortion (200-3500 Hz) .....	1 percent
Input impedance .....	50 ohms
Output impedance .....	600 ohms
Dimensions .....	1 1/4 x 1 1/4 x 5 1/2 in.
Weight .....	16 ounces
Plug .....	11-pin, Amphenol 86CP11
Monitor jacks .....	Front panel (output)
Ac ripple .....	2-mV max. on 48V dc

(13) TLC-400 Power Amplifier data:

Gain .....	33 dB
Power output .....	2 watts max.
Type .....	Class AB, power amplifier, transistor type (4 used).
Distortion .....	Less than 4% at 2W, 1000 Hz
Input impedance .....	600-ohms
Output impedance .....	8-ohms (loudspeaker)
Frequency response .....	±2 dB 200-3000 Hz (relative to 1000 Hz)
Power requirements .....	105 ma, 48V dc
Idle power drain .....	10 ma 48V dc
Dimensions .....	1 1/4 x 1 1/4 x 7 1/2 in.
Weight .....	18.5 ounces
Plug .....	11 pin Amphenol 86CP11
Monitor jacks .....	Front panel (output)

b. Intercommunication Station LS-626/FSC

(3) Power requirements .....	48V dc, 0.4 ampere maximum
(5) Number of channels .....	2
(6) Input impedance .....	600-ohms
(c) Output impedance .....	600-ohms
(5) Input level (listen) .....	-6 dBm
(6) Output level (talk) .....	-6 dBm
(7) Mounting requirements .....	Standard 19 inch relay rack
(8) Vertical clearance .....	3.5 inches
(9) Fuse requirements .....	1-48V, 1 ampere, GBA type
(10) Dimensions .....	5 1/4 x 12 x 19 in.
(11) Weight .....	10 lb.

1-7. Comprising an Operable Equipment Intercommunication Station LS-626/FSC (Remote Intercom) (FSN 5830-281-3845) and Intercommunication Station (Central Intercom) (FSN 5830-285-5330) comprise an operable equipment. No additional items are required.

1-8. Description (fig. 1-1)

a. *Central Intercom.* The central intercom unit consists of a 20-channel chassis designed for flush mounting in a standard 19-inch relay rack. It contains three plug-in, solid state module amplifiers, and requires 48-volt dc power from the station dc power source. The front panel contains a push-to-talk (LISTEN-TALK) switch, and 20 push-button operated channels with an unused spare button. Each of the channel pushbuttons illuminates when depressed or when the corresponding channels are selected at remote units. An audible alarm is provided to act as a calling signal. A RING pushbutton provides a calling signal for the channel called or calling. A VOLUME control allows local adjustment of loudspeaker output level. The loudspeaker also acts as a microphone in talk operation. A release (REL) pushbutton is provided to simultaneously release all channels selected. An OFF-ON toggle switch is provided to control the dc power input to the unit, and a self-indicating fuse is provided for protection of the unit.

b. *Remote Intercom.* The remote intercom unit consists of two-channel chassis designed for flush mounting in a standard 19-inch relay rack. It contains two plug-in solid state module amplifiers and requires 48 volt dc power from the station dc power source. The front panel con-

has a push-to-talk LISTEN-TALK switch, an ON-OFF toggle switch to control application of power, a RING pushbutton for calling, and a VOLUME control for local output control. A self-indicating fuse is provided for dc power protection. Five pushbuttons are provided to moni-

tor or operate on either channel A or B, with one button used as a release. A panel-mounted loudspeaker provides the voice output for listening operation, and also acts as a microphone for talk operation.



## CHAPTER 2

**INSTALLATION**Section I. **SERVICE UPON RECEIPT OF EQUIPMENT**

## 2-1. Packaging Data

One Intercommunication Station LS-626/FSC or LS-627/FSC is packed in a box with adequate packing and waterproof barrier materials to protect the equipment with reasonable care, and from exposure to the elements. The plug-in assemblies are fastened in place in the chassis and the equipment is shipped ready for use. The box measures 6 x 15 x 22 inches and weighs approximately 30 pounds.

## 2-2. Unpacking Instructions

a. Place the packed equipment in the area where the equipment will be installed.

b. Remove the remote intercom units and place them to one side, then remove the central intercom units and install them at the central location. Then install the remote intercom units at their proper locations in the 19 inch racks.

**CAUTION**

Be careful in unpacking and handling the equipment. If damaged, the equipment may be rendered useless and a complete overhaul may be required.

## 2-3. Checking Unpacked Equipment

a. Inspect the equipment for damage that may

have occurred during shipment. If the equipment has been damaged, fill out and forward DD Form 6 (para 1-35).

b. Check to see that the equipment is complete as listed on the packing slip. If a packing slip is not available, check the equipment against items listed in paragraph 1-7. Report all discrepancies in accordance with TM 88-750. The equipment should be placed in service even though a minor assembly or part that does not affect proper functioning is missing.

c. Check to see whether the equipment has been modified. If the equipment has been modified, the MWO number will appear on the front panel near the nomenclature plate. Check also to see whether all MWO's current at the time the equipment is placed in use have been applied.

**NOTE**

Current MWO's applicable to the equipment are listed in DA Pam 310-7.

d. Check the latest issue of DA Pam 310-4 (never more than 1 year old) and its latest changes (never more than 6 months old) to see whether you have the latest editions of all applicable maintenance literature.

Section II. **INSTALLATION INSTRUCTIONS**

## 2-4. Tools and Test Equipment

The tools and test equipment required for installation of the intercom units are listed in the maintenance allocation chart (MAC) (app. C).

## 2-5. Preinstallation Assembling

**A. Central Intercom Unit (fig. 2-1).**

(1) See that the three solid state amplifier modules TLC-409(2) and TLC-503 are installed in their plug-in sockets and that angle supports are securely fastened into place.

(2) Make certain that all assembly and part mounting hardware is securely fastened and there are no loose or poorly soldered connections.

**b. Remote Intercom Unit (fig. 2-2).**

(1) See that the two solid state amplifier modules TLC-409 and TLC-503 are installed in their plug-in sockets and that the angle supports are securely fastened in place.

(2) Make certain that all assembly and part mounting hardware is securely fastened and that there are no loose or poorly soldered connections.

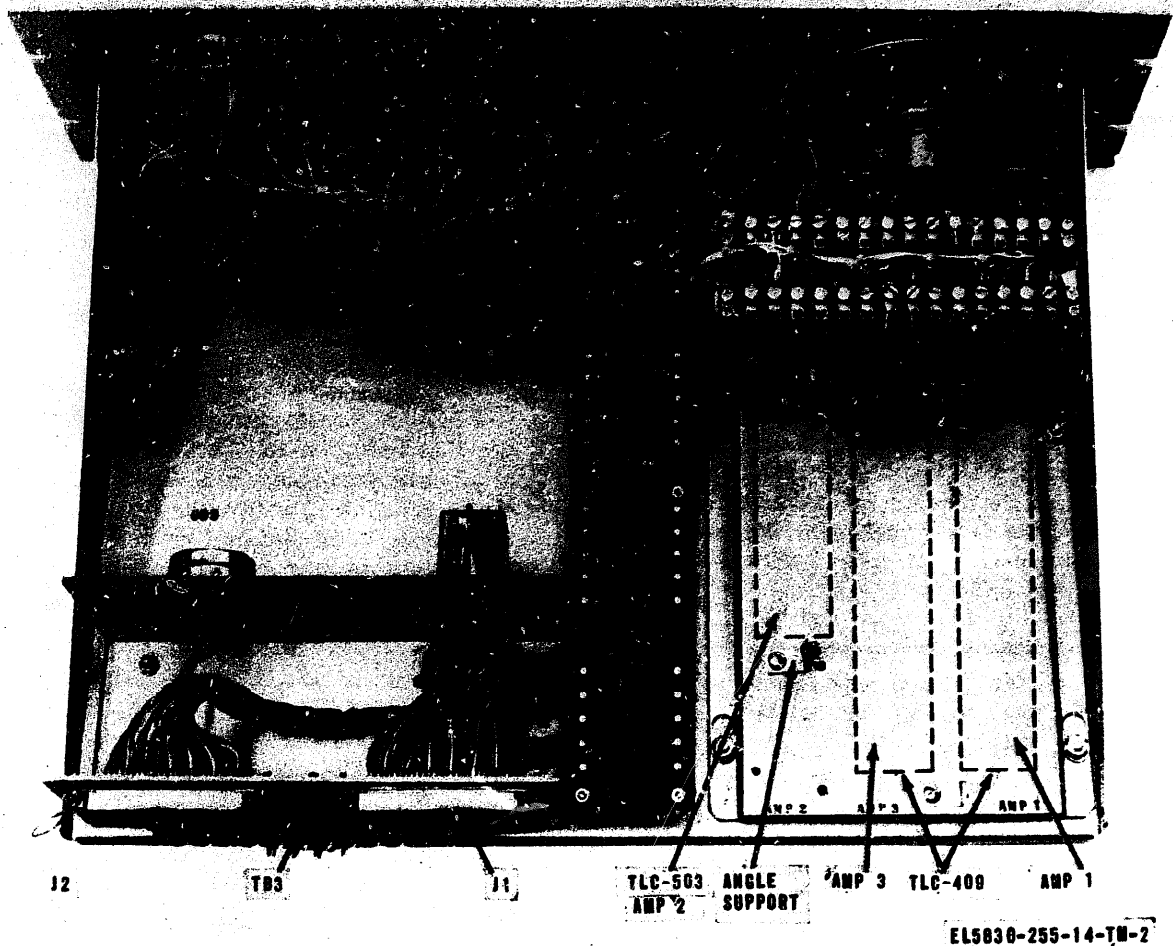

Figure 2-1. Central intercom, internal view.

**2-6. Installation Procedures**

a. *General.* Installation at some locations may require deviations from the details and instructions described in this paragraph for a typical Intercom station. Prior to installation, review each power distribution and wiring layout for any deviation required from these instructions.

b. *Central Intercom Unit.*

(1) Install each central intercom unit into the designated relay rack at the location at which it is to be used.

(2) Fasten the unit in place with four fil-  
lister head screws and cup washers.

(3) Connect the station power source of 48 volts dc to terminals 1 and 2 of TB3, the barrier strip at the rear of the unit (fig. 2-1). Connect

the positive lead to terminal No. 1 and the negative lead to terminal No. 2.

**CAUTION**

Make certain the power switch feeding the equipment is turned off.

(4) Connect the external cable (from the station main-frame (CDF) to connector plug P1 which mates with J1 on the rear of the unit. Likewise, connect a cable from the main-frame to connector plug P2 which mates with J2. Make certain that the VF (T and R leads) are connected as a cable pair.

(5) Perform installation check as described in paragraph 2-7.

c. *Remote Intercom Unit.*

(1) Install each remote intercom unit into

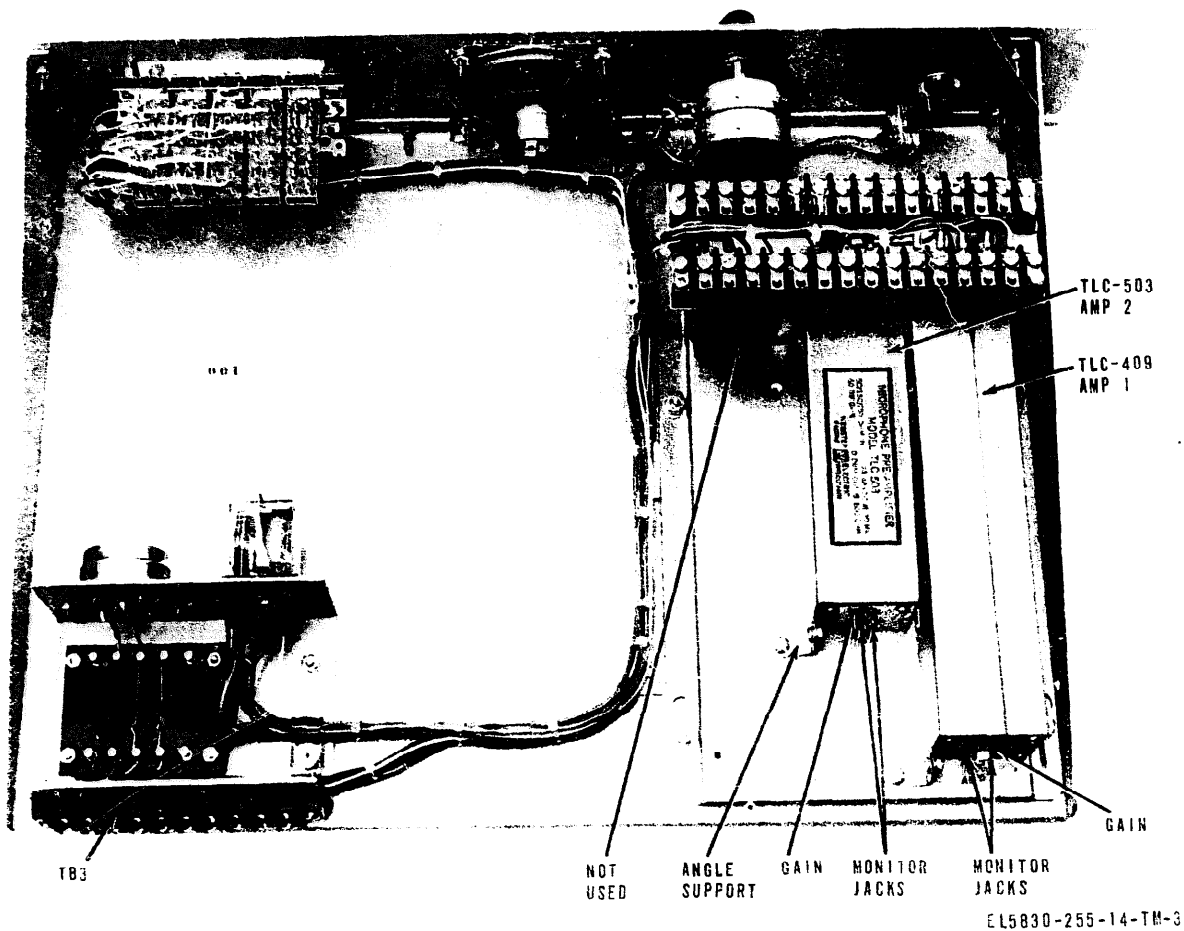

Figure 2-2. Remote intercom, internal view.

the designated rack at the location it is to be used.

(3) Fasten the unit in place with four fil-  
lister head screws and cup washers.

(3) Connect the station power source of 48  
volts dc to terminals 1 and 2 of TB3 the barrier  
type terminal strip at the rear of each unit (fig.  
2-2). Connect the positive lead to terminal No.  
1 and the negative lead to terminal No. 2.

**CAUTION**

Make certain that the station power  
switch feeding the equipment is turned  
Off.

(4) Connect external cable leads to channel  
A terminals 3, 4, 15, and 6, and channel B ter-

minals 7, 8, 9, and 10. The VF terminals must  
be connected as a cable pair.

(3) Perform installation check as described  
in paragraph 2-7.

*d. Interconnecting Wiring (fig. 2-4).* All in-  
terconnections between remote units and between  
the remote and central intercom units are made  
at the station main frame (on a cross connect  
basis). Depending upon system requirements the  
following basic connection options are possible.

(1) A remote channel may be directly cross-  
connected to another remote channel without the  
central intercom unit being connected. This per-  
mits one remote to talk directly to another re-  
mote on a private line basis.

(2) Both channels of a remote intercom

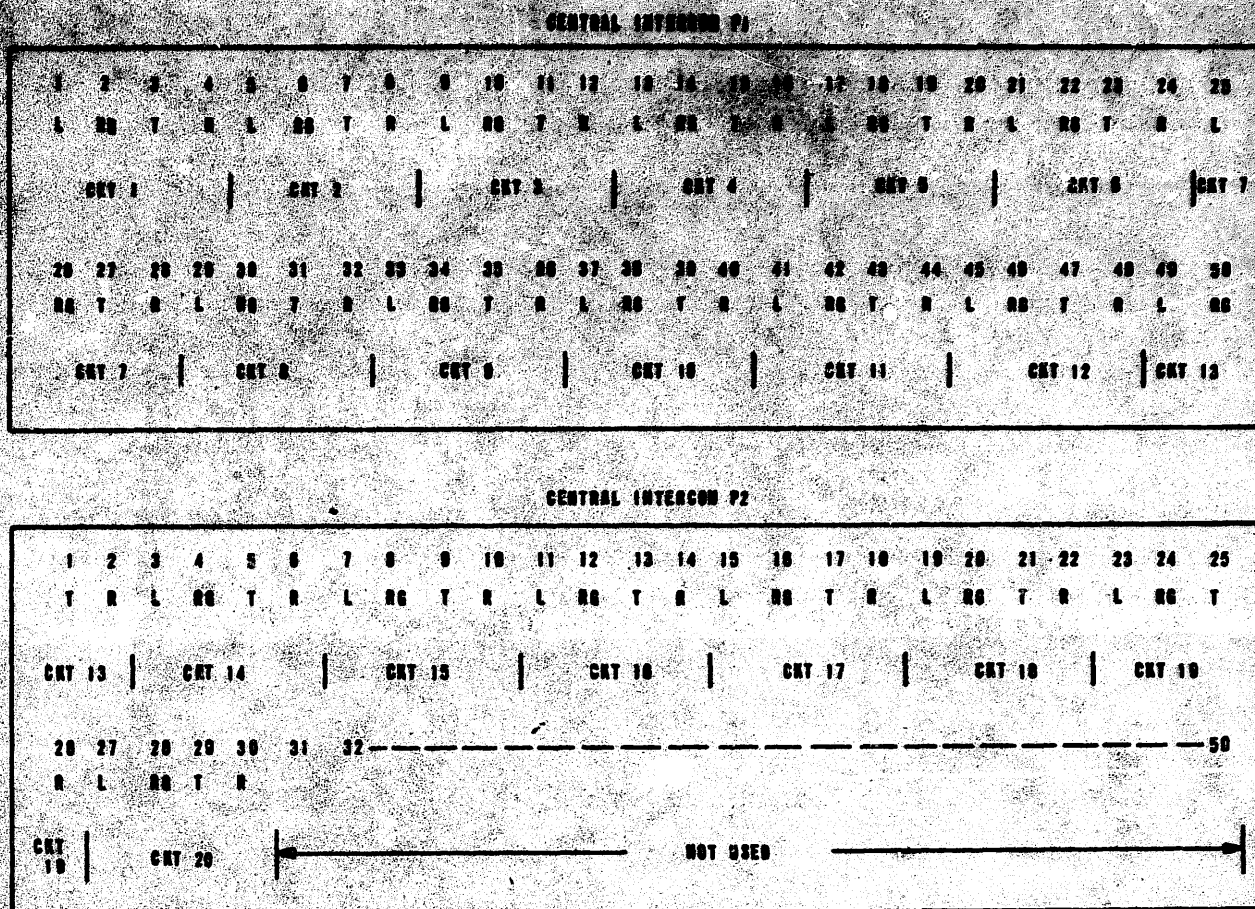

EL5830-255-14-TM-10

Figure 2-3. External wiring of P1 and P2.

unit may be cross-connected to separate channels on the central intercom unit.

(3) Either channel on a remote intercom station may be cross-connected to other remote intercom units as well as to the central intercom unit.

**NOTE**

When making cross-connections, be sure to connect corresponding tip and ring (VF) leads and also corresponding ring and lamp leads.

(4) When cross-connecting a channel connect the following corresponding leads:

- L to L ..... (lamp lead)
- RG to RG ..... (aural alarm lead)
- T to T ..... (VF tip lead)
- R to R ..... (VF ring lead)

(5) When wiring is completed install the channel designation on the panel designation strips (above pushbuttons) to identify the channel.

**2-7. Initial Check and Adjustment of Equipment**

a. Place all off-on switches in their OFF positions.

**NOTE**

Equipment adjustments are normally set at the factory for proper input and output levels. If any of the following adjustments cannot be made DO NOT proceed any further. Refer to the corrective maintenance procedures (chap. 5).

b. See that 48V dc is supplied to terminals 1

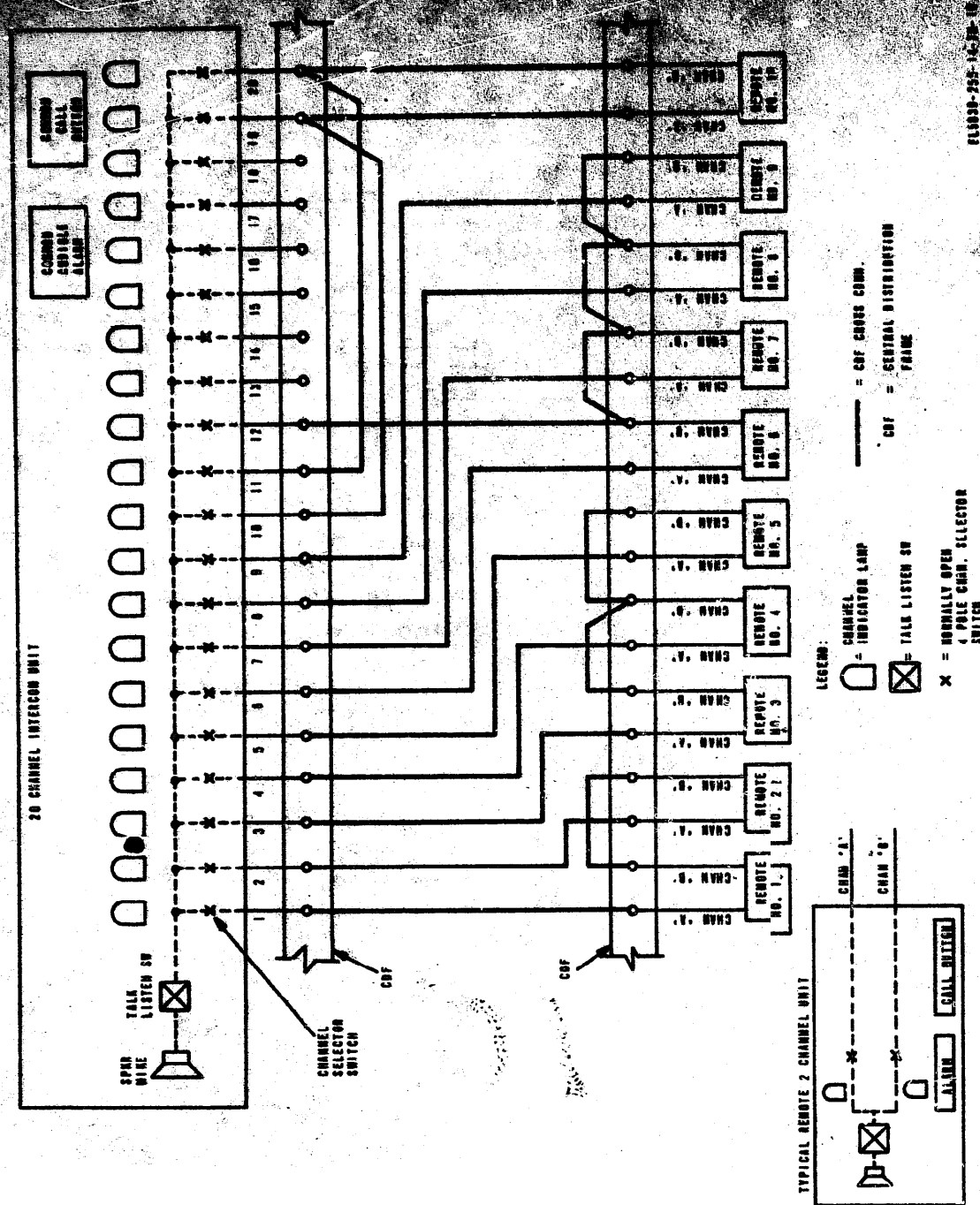

Figure 2-4. Typical intercom cross-connect diagram.

and 2 of TES when the station power switch is turned ON, and proceed as follows:

(1) Set power OFF-ON toggle switch to ON.

(2) Depress button 1 (channel No. 1) on front panel together with RING pushbutton. Note that channel 1 lamp illuminates and that audible alarm operates.

(8) Depress REL pushbutton and note that number 1 channel light extinguishes and that the pushbutton returns to its normal position.

(4) Perform steps 4 and 6 for all 20 pushbuttons, one at a time, and note that lamps and audible alarm operate properly.

c. Arrange for two or more persons to participate in tests between the central intercom unit

and the remote intercom stations and proceed as follows:

(1) At the Remote intercom under test check that 48V is supplied to terminals 1 and 2 of TBS.

(2) Set VOLUME at halfway position. Set LISTEN-TALK switch to LISTEN, press and release REL button, set power OFF-ON toggle switch to ON and check that the panel fuse does not indicate as blown.

(3) Depress OPER A pushbutton and RING pushbutton. Note that OPER A pushbutton illuminates and that audible alarm operates.

(4) Depress REL pushbutton and note that OPER A pushbutton light is extinguished and the button returns to its normal position.

(5) Repeat steps 3 and 4 substituting channel B (OPER B) instead of A. The OPER B button should illuminate, and the alarm should indicate when the RING button is pressed.

(6) Depress LISTEN-TALK switch to TALK position and also depress OPER A, or OPER B, button and request central intercom to speak. release LISTEN-TALK switch and check that a reply is heard in LISTEN position.

Adjust VOLUME control for satisfactory volume, if necessary.

(7) Have central intercom speak first on channel A (No. 1) and then channel B (No. 2). Depress remote intercom intercom MON A button first, and then MON B button, and check that these channels can be monitored. The monitor buttons will not illuminate but will stay in until released. Press REL button to release any of the pushbuttons.

(8) If satisfactory TALK or LISTEN operation is not obtained, the gain of the amplifiers must be readjusted or the defective amplifier must be replaced.

(9) On the central intercom set LISTEN-TALK switch to TALK, depress channels 1 through 20 pushbuttons and request the associated remote unit to speak. Set TALK switch to LISTEN and check that a reply can be heard. Adjust VOLUME control for a satisfactory volume. Repeat this step for the associated station.

(10) If satisfactory TALK or LISTEN operation is not obtained the gain of amplifiers 1, 2, or 3 must be adjusted, or the defective amplifier must be replaced.

## CHAPTER 3 OPERATION

### Section I. OPERATOR CONTROLS AND INDICATORS

#### 3-1. General

This section provides information pertaining to the location, description, and function of controls and indicators for the central and remote intercom stations.

#### 3-2. Controls and Indicators

a. The controls and indicators of the intercom system are located on the front panels of the central intercom unit and the remote intercom units as shown in figures 3-1 and 3-2.

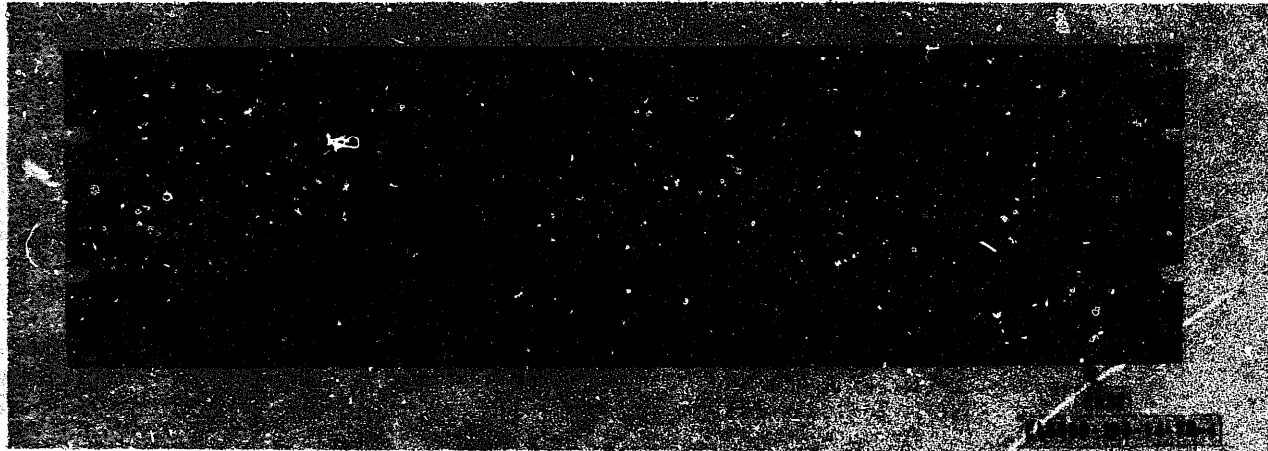

*Figure 3-1. Central intercom unit, controls and indicators.*

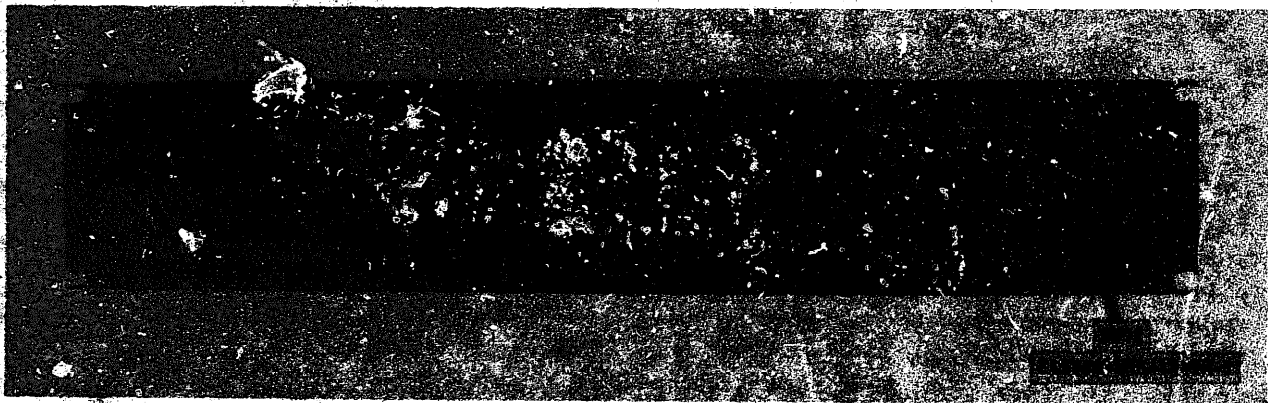

*Figure 3-2. Remote intercom unit, controls and indicators.*

**d. Central Intercom Unit Controls and Indicators (fig. 3-1).**

Control or Indicator	Function
Loudspeaker (LS-1).	Provides voice frequency output in listen operation, and acts as a microphone in talk operation.
LISTEN-TALK switch.	Spring loaded lever switch. Provides listen operation with switch in LISTEN position, and talk operation in TALK position.
RING pushbutton switch.	When depressed, operates aural alarm inside the unit and at the called location.
ON-OFF toggle switch.	Controls application of 48V dc power to unit.
VOLUME control.	Controls audio output of loudspeaker in listening operation; has no effect in talk operation.
Fuse (F-1).	Indicator type, protects dc power input line and shows red tip when blown.
Pushbutton channel switches (1 to 20).	Permits individual channel selection or any combination of up to 20 channels. Pushbuttons (S1 through S20) illuminate when channel is in use. Contains one spare unused and unmarked button. A push-to-operate, push-to-release feature is included.
REL pushbutton switch.	When depressed releases all channel pushbuttons that are depressed (when more than 5 pushbuttons are to be

**c. Remote Intercom Unit Controls and Indicators (fig. 3-2)**

Control or Indicator	Function
ON-OFF toggle switch.	Controls application of 48V dc power to unit.
Fuse (F-1).	Indicator type, protects dc power input line and shows red tip when blown.
RING pushbutton switch.	When depressed, operates aural alarm inside the unit and at the location called.
LISTEN-TALK switch.	Spring-loaded lever switch. Provides listen operation in LISTEN position and talk operation in TALK position.
VOLUME control.	Controls audio output of loudspeaker in listen operation; has no effect in talk operation.
Loudspeaker (LS-1).	Provides voice frequency output in listen operation, and acts as a microphone in talk operation.
Pushbutton channel switches OPER A and OPER B.	Provides operation on either channel A or B, as selected, and illuminates when channel is in use.
MON A or MON B pushbutton switches.	Provides monitor operation on either channel A or B, as selected. These buttons do not illuminate when used.
REL pushbutton.	When depressed releases the OPER and MON pushbuttons which are depressed.

**Section II. OPERATION UNDER USUAL CONDITIONS**

**3-3. General**

The intercom system normally operates from a central control location which can communicate with twenty separate locations on independent channels. Remote stations are provided with the capability of talking to each other or to the central intercom depending upon the channel strapping arrangement at the station main distribution frame (MDF). Channel buttons are illuminated while in operation to indicate that the channel is in use. The monitor buttons do not illuminate but remain pressed-in to indicate

which channel is being monitored. Monitoring pushbuttons are not supplied with the central intercom.

**3-4. Starting Procedure**

- a. Turn OFF-ON toggle switch to ON.
- b. Check that fuse does not indicate as blown.
- c. Set VOLUME control for desired listening level on any desired channel.

**3-5. Operating Procedure**

- a. Assuming that all remote and central in-



intercoms are turned on, operate the pushbutton of the channels desired to communicate with. Note that channel button illuminates at all stations connected to the channel.

b. Push in RING button, hold momentarily, and release. Note that an audible alarm sounds at the calling location while the RING switch is depressed. When more than one remote unit is connected to a channel, a coded ring such as 1 short and 1 long ring may be used.

At a called station (remote or central intercom) the aural alarm will sound and the illuminated pushbutton indicates the calling channel.

c. Hold the LISTEN-TALK lever switch in TALK position to answer a call, and speak to the calling station.

d. Release the LISTEN-TALK switch and await the reply from the distant end. Converse with distant party by alternately operating the LISTEN-TALK switch, as required.

e. Press REL button to switch off the channel in use or change channels, and note that channel lamp goes out and button also releases and returns to outposition.

### 3-6. Stopping Procedure

a. Turn ON-OFF toggle switch on both the remote and central intercom units to OFF.

b. Turn OFF the common station dc supply applied to both the central and remote intercom units.

#### NOTE

Normally the intercom system is left on, and is ready for operation for the full 24-hour daily period. They are only shut off when repairs or changes in wiring connections require it.

c. To release a channel at the remote station, momentarily depress then release REL pushbutton.

d. To release a channel at the central station depress the push-to-operate, push-to-release channel pushbutton that you desire to release. When more than one channel is to be released simultaneously, depress the REL pushbutton. If more than 5 pushbuttons are to be released simultaneously on the bottom row, a second operation of the REL pushbutton may be required.

CHAPTER 4

FUNCTIONING OF EQUIPMENT

4-1. Introduction

The 2-channel remote intercom and the 20-channel central intercom operate similarly except that a different number of channel switches and amplifiers are used. All amplifiers are solid-state devices using transistors. Two basic types of plug-in amplifiers are used. The TLC-503 type are microphone preamplifiers employed to provide sufficient drive from the loudspeaker-microphone to the type TLC-409 speaker and driver power amplifiers.

4-2. Intercom System Functional Block Diagram Description

Diagram Description  
(fig. 4-1)

a. The central intercom unit provides switching for twenty, two-wire voice frequency channels, providing listening, talking, indicating and ringing connections.

b. Power is supplied from the negative (-) 48-volt dc station source to each of the remote and central intercom units.

c. The remote unit intercoms are connected to the central station intercom or may be connected to each other depending upon station requirements.

4-3. Central Intercom Unit Circuit Analysis

(fig. F0-2)

a. *Listen Circuit.* With LISTEN-TALK switch S21 in the LISTEN position (normally open) relay K1 remains inoperative and AMPL-1, the output power amplifier (TLC-409) is through connected, with 48V dc power applied through contacts 8 and 9 of TLC-409 and TB1-13 and 14, respectively, and audio through the VF leads and contacts A and B of S1 through S20 (the channel selector switch for each channel). The VF signal is applied to the amplifier AMPL-1 and drives loudspeaker LS1 under control of L-pad VOLUME control AT1.

b. *Talk Circuit.* When the LISTEN-TALK

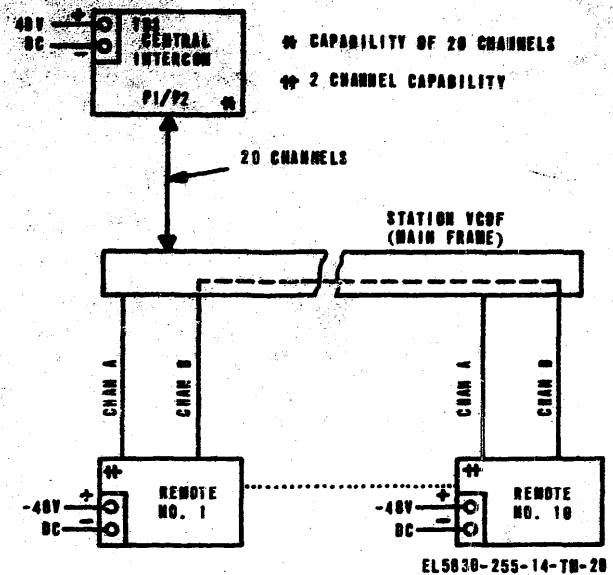

Figure 4-1. Control and remote intercom system functional block diagram.

switch S21 is held at TALK, it connects the coil of relay K1 to 48V dc causing relay K1 to operate, switching the loudspeaker (LS1) terminals to the input of microphone preamplifier TLC-503 (AMPL-2) the audio output of which is applied through a fixed 30 dB attenuator pad comprised of resistors R3, R4, and R6 to the input of talk power amplifier TLC-409 (AMPL-3). The output of this amplifier is applied through closed contacts 3 and 4 of relay K1, contacts A and B of the channel in use (S1 through S20) to the VF line connections for that channel on jack J1 or J2, supplying audio to the associated remote station. Amplifier AMPL-3 is used to provide capability to drive all 20 remote lines if used simultaneously, and is nominally adjusted for a -6 dBm output across 10-ohm load resistor R2.

e. *Aural and Visual Alarm and Control Circuits.* When RING pushbutton S22 is depressed, alarm DS21 sounds at the central intercom unit

arid & o a I h m c i a t e d ~ ~ i n ~ t u l 3 t a that have been selected by depressed pushbuttons S1 through S20 on a selected basis. The R (ring) lines provided for each channel from 1 through 20 are used to connect the negative dc from the associated ring button (either local or remote) through section C of pushbutton switches S1 through S20. current limiting resistor R1 is used to limit the current flow through DS1. Channel lamps DS1 through DS20 are illuminated on an incoming call by the application of -48V on the R leads from the remote stations. They will also illuminate on calls originated from the central unit through the D contacts of pushbutton selector switches S1 through S20. Release button (marked REL) operates and closes contact D operating release relay K2, which actuates the mechanical release mechanism of the selector switch. An unused and unmarked spare button is provided.

*d. Power Circuit.* The 48-volt dc supply is protected by indicating type fuse F1 rated at 2 amperes, and controlled by ON-OFF toggle switch S23, placed in the negative lead from terminal 2 of TB3. Terminal 1 of TB3 is strapped to terminal 3 to provide a positive common return from the selector switch lamps DS1 through DS20, talk relay K1, and to alarm DS21 through protective and voltage dropping resistor R1. Thus, operation of all active components is completed by controlling the negative lead. All amplifiers are permanently connected to the power supply through pin terminals 8 (-) and 9 (+) on the modules, TB1-13 and 14, respectively.

Terminals 4 through 8 of TB3 are strapped together to supply 8 negative voltage through contacts D of S1 through S20 to provide a local and remote lamp indication when a channel selector pushbutton is operated, thereby indicating the channel in use.

#### 4-4. Remote Intercom Unit Circuit Analysis (fig. F0-3)

##### *a. Listen Circuit.*

(1) In the LISTEN position, LISTEN-TALK switch S1 and relay K1 remain inoperative, and output power amplifier TLC-409 is ready for operation with 48V dc applied to module power terminals 8 and 9. When MON A switch is depressed, selector switch S4B-1 and S4B-2 connect terminals TB3-3 and TB3-4 to the audio (VF) line of channel A to AMPL-1. The incoming VF is applied to the TLC-409

audio power amplifier and the output is applied through L-pad volume control AT1 to speaker LS1, thus channel A is monitored. MOD A pushbutton is not illuminated. pushbutton selector switches S4A-B are mechanically interlocked so that operation of any one button releases the previous selection. Channel A audio input is connected through terminals S4C-1 and S4C-2, terminals TB1-1 and TB1-2 to amplifier 1. The output of amplifier AMPL-1 is applied to the VOLUME control AT1 and loudspeaker LS1 to produce the audio output from channel A. At the same time, S4C-4 connects the negative lead to lamp DS2, and, since DS2 is also permanently connected to the positive power terminal, channel A (OPER A) lamp is illuminated.

(2) Channel B is monitored similarly through selector switch S4D- and S4D-2. Channel B is operated through the OPER B button controlling selector switches S4E-1 and S4E-2, and channel B lamp DS3 (OPER B) is illuminated through S4E-4.

(3) Indicator lines L5 and L9 on terminal board TB3 are connected to -48V dc whenever OPER channels A or B, respectively, are operated to power the channel indicator at the remote stations.

(4) Whenever channel A or channel B is operated, selector switch S4C-3 or S4E-3 connect -48V dc to diode CR1, or CR2, respectively. This forward biases the diodes, connecting aural alarm DS1 through push-to-call (RING) switch S2, when the RING button is pressed, causing the illuminated channel to ring at both local and called locations.

*b. Talk Circuit.* When the LISTEN-TALK switch is set to the TALK position, S1 connects relay K1 to negative 48V dc through contacts 1 and 2 and switches loudspeaker LS1 to the input of microphone preamplifier TLC-503, and the output of amplifier AMPL-2 to the selector switches through relay contacts 3 and 4. Thus, the talk output is connected to the VF lines through either channel A or channel B OPER pushbutton, the output is adjusted for 8 nominal -6 dBm.

*c. Power Circuit.* The 43V dc supply from the station source is controlled through fuse F1, an indicating type fuse rated at 1-ampere, and toggle switch S3 is placed in series with the negative lead from terminal 2 on terminal board TB3. The positive lead of the power supply from TB3-1 is permanently connected to the selector

switch lamps DS2 and DS3 and to talk relay R1, also to alarm DS1 through protective and voltage dropping resistor R1.

#### 4-5. Amplifier Modules

##### a. *Microphone preamplifier TLC-503 (fig. FO-4).*

(1) The microphone preamplifier module is a self-contained plug-in unit connected through an 11-pin plug. Three PNP transistor amplifier stages connected in the common-emitter circuit are used. Fixed bias is employed with capacitive coupling between stages.

(2) The inputs and outputs are transformer coupled through T1 and T2, respectively, and have tapped windings for selectable impedances. In the intercoms they are connected for 50-ohm input through pins 1 and 10 of TB1 and for a 600 ohm output through pins 3 and 4. The two center-tapped output windings are jumpered together as shown in the schematic. Monitor jacks J1 and J2 are connected to the output winding and placed on the front of the module for checking the output without removing the cover. The input is adjustable through variable gain control R3, which can be adjusted externally and locked in place.

(3) The 48-volt dc station power supply is connected through pins 8 and 9. Terminals 8 and 9 are used only for power on all modules, with pin 8 always being the negative terminal and pin 9 always the positive terminal. A protective diode, CR1, is connected in series with the positive lead so that the circuit will be open if polarity is reversed; polarity must be correct to provide forward bias for the units to operate. Hence, reversal of polarity will not damage the transistors. A protective decoupling and voltage dropping resistor, R18, is connected in series with the negative lead; in this unit it is an 850-ohm 2-watt type and provides a -24 Vdc reference and operating voltage from the 48-volt source. A separate chassis ground connection is provided.

(4) Gain is adjustable from 0 to 60 dB, and the output is rated at 0 dBm with a maximum of +15 dBm being obtainable. A maximum

ripple voltage of 3 mV can be tolerated in the power supply to attain minimum noise levels.

##### b. *Power Amplifier TLC-409 (fig. FO-5).*

(1) The power amplifier module is a self-contained solid-state plug-in unit connected through an 11-pin plug. Four transistors are used. Fixed bias is employed with capacitive coupling to the driver stage, and transformer coupling to the input and output stage.

(2) The driver stage is a PNP common-emitter connected stage with selectable input impedances provided by windings on T1. Pins 1 and 2 on TB-1 provide a 600-ohm input, and a 8-ohm output through pins 3 and 4. The output winding is center-tapped but the center tap is not used in this connection. Monitor jacks J1 and J2 are provided on the front panel of the module for checking the output without removing the cover. The input is adjustable through variable gain control R1, which can be adjusted externally and locked in place.

(3) The 48-volt dc station supply is connected through pins 8 and 9. Pin 8 is the negative terminal and pin 9 is the positive terminal. Protective diode CR2 is connected in series with the positive lead so that the power circuit will be opened if the polarity is reversed; polarity must be correct to provide forward bias for the units to operate. Hence, reversal of polarity will not damage the transistors.

(4) Feedback is provided in the output stage to produce a 2-watt output with low distortion and high stability. The feedback is controlled through output from winding sec 2 on output transformer T3, and controlled by diode CR3 and transistor Q4. Diodes CR1 and CR1A prevent overdriving and peak limiting. Thermal stabilization is also provided to produce maximum output and prevent runaway. Output transistors are NPN type.

(5) An overall gain of 33 dB is provided, and, with an input of 0 dBm a full 2-watt output can be obtained with less than 4 percent distortion at 1000 Hz. A minimum idling current of 10 ma is used at 48V, maximum drain is 105 ma.

CHAPTER 5

**MAINTENANCE**

**WARNING**

**DANGEROUS VOLTAGE**

Death or Serious injury may result from accidental contact with 115 volts ac or -48 volts dc power present in the equipment.

5-1. Scope of Maintenance

a. This chapter contains instructions for performing preventive and corrective maintenance procedures for the remote and central intercom units. The scope of maintenance is assigned by the maintenance allocation chart (app C).

b. Maintenance of the remote and central intercom units includes:

- (1) Preventive maintenance checks and services (para 5-3e through 5-3g).
- (2) Corrective maintenance procedures (paras 5-5 and 5-6).
- (3) Removal and replacement procedures (para 5-7).
- (4) Adjustment procedures (para 5-9).

5-2. Tools, and Test Equipment Required

The tools and test equipment required for maintenance of Intercommunication Stations LS-626/FSC and LS-627/FSC are listed and identified in the maintenance allocation chart (app C).

5-3. Preventive Maintenance

a. **General.** Preventive maintenance is the systematic care, inspection, and servicing of equipment to maintain it in serviceable condition, prevent breakdowns, and insure maximum operational capability. Preventive maintenance includes the inspection, testing, and replacement

**c. Weekly Preventive Maintenance Checks and Services.**

Sequence No.	Item	Procedure	Reference
1	Panel condition	Clean panel exterior surfaces.	Para 5-3c.
2	Cabling	a. See that cable insulation is not cut or cracked or abraded:	

of assemblies that inspections and tests indicate would probably fail before the next scheduled periodic service.

b. **Preventive Maintenance Checks and Services Periods.** The preventive maintenance checks and services for the equipment are given in subparagraphs e through g below. These checks and services must be performed during the specified periods. Records and reports of the preventive maintenance checks and services must be made in accordance with the requirements set forth in TM 38-750.

**c. Cleaning.**

- (1) Remove accumulated dust and dirt from rack interiors using a vacuum cleaner with plastic nozzle hose and a dust brush.
- (2) Clean rack and panel exteriors, using a vacuum cleaner with plastic hose nozzle and a dust brush or a clean, dry, lint-free cloth.
- (3) Wipe panels clean with a lint-free cloth when only dust is present.

**WARNING**

The fumes of trichloroethane are toxic. Provide thorough ventilation whenever used. Do not use near an open flame. Trichloroethane is not flammable but exposure of the fumes to an open flame converts the fumes to a highly toxic, dangerous gas.

(4) Remove smudges or any dirty surface areas of the panels or chassis by wiping with a clean, lint-free cloth moistened with trichloroethane. Wipe dry with a clean dry cloth.

d. **Refinishing.** Remove rust and corrosion from metal surfaces. Insure that the proper paint is used. Refer to the applicable cleaning and refinishing practices specified in TB 746-10.

Sequence No.	Item	Procedure	Reference
		repair insulation, cuts, cracks and abrasions with electrical insulation tape as necessary.	
		b. Tighten loose connections.	
		a. Remove kinks and strains.	

**f. Monthly Preventive Maintenance Checks and Services.**

Sequence No.	Item	Procedure	Reference
1	Publications	Check to see that all publications are complete and current.	App A.
2	Modification work orders	Check to see if any MWO's are required. Check the system to see if current MWO's have been applied and that the MWO number is stamped as required. Perform or request modifications as applicable.	Applicable MWO (see DA PAM 810-7)

**5-4. Corrective Maintenance**

If trouble is encountered during normal operation, check local indications for information as to the type of fault. Check fuses for any indication of excessive current flow. Attempt to restore normal operation by replacing any blown fuses or resetting the primary power source circuit breaker. Inspect external wiring connections to insure that they are securely fastened. Replace any indicator lamps that do not indicate, when operated, to determine if the lamp or line is at fault. For information on wiring connections refer to paragraph 2-6d. If trouble still persists, perform the operational and troubleshooting procedures (para 5-6 and 5-7) to isolate the fault, after complying with the preliminary test procedure of paragraph 5-5. Remove or replace any defective assembly or component as detailed in paragraph 5-8.

power supply to the intercoms, notify the maintenance supervisor to ascertain that no other equipment will be removed from operation.

b. Use station personnel at the remote and central stations and check out one channel at a time.

**5-6. Operational Test**

a. *General.* The operational tests provide a check on the overall performance of the intercom system under operating conditions. Since the intercom system is a voice frequency telecommunications system between the central station and maintenance activities at the remote intercoms, and operators' access units, the operational test consists of a talk-listen check on each channel and an observational check of whether proper indicating and alarm conditions are present. If abnormal operation exists while performing the operational tests, refer to the troubleshooting procedures in paragraph 5-7.

**5-5. Preliminary Test Procedure**

a. Prior to turning off the 48-volt dc station

b. *Operational Test Chart.*

Step No.	Test	Test procedure	Normal indication
1	DC input voltage, ON-OFF switch and fuse operation.	Connect multimeter test leads between TB1-13 and ground TB1-14. Connect positive lead to TB1-14.	With power switch ON, meter indicates -48V dc ±10%. With power switch OFF meter indicates 0 V dc.
2	Channel continuity and pushbutton switch.	Push in any channel button 1 to 20 on central intercom unit, or OPER A or OPER B on remote intercom unit.	Channel button lamp should light, indicating that lamp and line are operating. (MON buttons will not light).
3	Alarm line and ring circuit.	With any channel button depressed, press RING button.	Central intercom alarm should operate as well as remote alarm.
4	Talk-listen circuit, lines, and switch.	Depress central intercom LISTEN-TALK switch to TALK position, request a reply, and release. (Use any channel)	Remote intercom user should hear and answer. Central intercom unit should hear reply.
5	Volume control, and amplifier operation.	Vary VOLUME control while listening to a remote or central station.	Note that volume can be increased or decreased by control setting.

## 5-7. Troubleshooting Procedures

a. Troubleshooting procedures for the central and remote intercom system are given in the troubleshooting chart in subparagraph c. below. All troubleshooting and maintenance of the central and remote intercom units shall be in accordance with the maintenance allocation chart (app C).

b. From the operational tests (para 5-6), note

## c. Troubleshooting Chart.

Item No.	Malfunction	Probable cause	Corrective action
1	No input voltage to either central or remote intercom units.	a. Open dc supply circuit fuse. b. Blown panel fuse.	a. Replace supply fuse. b. Replace with equivalent fuse and energize using proper turn-on procedure (para 2-7b and c (1)).
2	Channel selector pushbutton switch will not illuminate, when depressed.	a. Channel lamp. b. Channel switch.	a. Check voltage on associated channel L-line with multimeter for -48V dc indication to TB1-14. If voltage is present replace channel lamp. b. If voltage is not present check channel switch section D on central intercom unit, or section 4 on remote intercom unit, for continuity. If switch continuity exists, check wiring between "L" line terminal on TB8, or J1 or J2; also check wiring between terminal 4 and switch on central intercom unit, or terminal 2 and switch on remote intercom unit.
3	Channel button lights, but aural alarm will not operate when RING button is pressed on a specific channel.	a. Channel switch. b. Isolation diode.	a. Check for -48V dc indication from "R" line (-) to TB1-14(+) with multimeter. If voltage does not exist, check channel switch section C on central intercom unit, or section 4 on remote intercom unit, for continuity. b. Check front to back resistance of applicable diode CR1 thru 20 in central unit, or CR1 thru 4 in remote unit. If diode is good, it will indicate a 10 to 1 or better front to back ratio.
4	Alarm will not operate when RING button is pressed (on any channel).	a. Dropping resistor R1. b. Aural alarm DS21 or DS1 on central and remote intercom units, respectively. c. RING switch.	a. If diode is good, check R1 for proper resistance value (1200 ohms) with ohmmeter. b. Check alarm with an ohmmeter. (Nominal forward resistance is 1 to 2 thousand ohms, and is greater than 20,000 ohms in reverse direction.) c. Remove power from the unit and check for continuity across the ring switch when it is de-

the apparent trouble symptom. Locate the malfunction in the troubleshooting chart (c below), note the probable cause, and take appropriate corrective action. Whenever a component or assembly is replaced, repeat the applicable operational test procedure to verify proper operation of the replacement item. Before performing the corrective actions for a particular system, inspect all wiring and connections which affect the problem area.

Item No. 4 (Cont)	Malfunction	Probable cause	Corrective action
5	<b>LISTEN circuit inoperative.</b>	<ul style="list-style-type: none"> <li>d. Defective wiring.</li> <li>e. Defective remote talk circuit.</li> <li>b. Defective loudspeakers.</li> <li>a. Defective VOLUME control.</li> <li>d. Defective or misadjusted TLC-409 amplifier module.</li> <li>e. Defective channel switch.</li> <li>f. Defective wiring.</li> <li>g. Defective relay K1 contacts.</li> </ul>	<p>depressed and on top contact when pressed in.</p> <ul style="list-style-type: none"> <li>d. Check wiring with ohmmeter for continuity between TB3-1, ring switch S2, resistor R1 and DS21 or DS1 alarm.</li> <li>a. Request reply from another remote channel to isolate the remote circuit.</li> <li>b. Check voice coil of speaker for continuity with ohmmeter, and note if click is heard when test prods are applied to voice coil. Continuity and a click indicate speaker is operable.</li> <li>e. Check value and continuity of 8-ohm L-pad, AT1, with ohmmeter.</li> <li>d. Apply -6 dBm/600-ohms, 1000 Hz tone from audio signal generator to any "VF" line (channel button of selected "VF" channel must be pressed in). Check for a <math>2 \pm 0.2</math> V rms output indication across TB1-3 and 4 or MON jacks 1 and 2 on front of module, using ac voltmeter.</li> <li>e. Check contacts A and B on central intercom unit, or 1 and 2 on remote intercom unit, channel switch for continuity with an ohmmeter.</li> <li>f. Check wiring between components and intercoms for continuity with an ohmmeter.</li> <li>g. Check contacts 1 and 2 of K1 for continuity.</li> </ul>
6	<b>Defective TALK circuit.</b>	<ul style="list-style-type: none"> <li>a. Defective loudspeaker (microphone).</li> <li>b. Talk relay K1.</li> <li>c. Preamplifier module TLC-503.</li> <li>d. Attenuator, R3 thru R6 (central intercom unit only).</li> <li>e. Amplifier TLC-409 (line driver). (central intercom only)</li> </ul>	<ul style="list-style-type: none"> <li>a. Check voice coil for continuity.</li> <li>b. Check that 48V dc is applied to coil terminals 1 and 2 on plug-in relay K1, using multimeter. Replace plug-in relay if inoperative.</li> <li>e. Apply approximately 0.7 mV rms at 1000 Hz to terminals 25 and 26 of TB2 (central intercom unit) or to terminals 5 and 24 of TB2 for remote intercom unit, and check output across monitor terminals J1 and J2 on module front panel for -16 dBm/600-ohm using ac voltmeter.</li> <li>d. Check value of resistors (fig. FO-2) with an ohmmeter. Replace if resistance varies more than <math>\pm 10\%</math>.</li> <li>e. Apply -6 dBm/600-ohm input at 1000 Hz from signal generator to terminal board TB2, terminals 27 &amp; 20 (attenuator</li> </ul>



Symptom (Cont)	Malfunction	Probable cause	Corrective action
7 Channel switch will not release.	f. Channel switch.	g. Defective wiring.	input), and check output at J1 and J2 on the module with ac voltmeter for 0.4V rms $\pm$ 30 mV. Replace module or adjust GAIN (para 5-8c.) as required.
	A. Remote unit.	a. Channel switch, mechanical linkage.	f. Check for continuity with ohmmeter section A & B, or 1 and 2 of central or remote intercom units, respectively for the channel in use. Replace switch if defective (para 5-8d.).
	b. Channel switch, electrical release coil a central intercom unit.	c. Channel switch contact, REL section D.	g. Check wiring with ohmmeter for continuity. "VF" leads only. Check between channel switch and TB-3 or 1 and J1, also to remote station terminal strip.
	8 Monitor function cannot be obtained on remote unit.	Channel switch of remote unit.	A. Replace remote intercom unit temporarily to determine if listen circuit at remote is at fault.
			c. Check mechanical operation of linkage on release switch (REL button S4A) on remote unit.
			d. See that -48 volts dc is applied to coil K2 when REL switch, section D, is pressed in to contact negative lead. Replace switch or coil if defective.
			e. Check continuity of switch "D" contacts with an ohmmeter.
			Check MON A or B button, switch sections S4-B or D, contacts 1 and 2, with an ohmmeter for continuity. Replace switches if defective.

**NOTE**

That volume can be increased or decreased by control setting. Solenoid coil K2 has rated power to release up to 5 pushbuttons simultaneously.

**5-8. Removal and Replacement Procedures**

**a. General.** Any defective component or assembly shall be removed and replaced using normal replacement techniques. Figures 1 and 2 illustrate the location of replaceable parts within all units of the system. Initial adjustments and operational tests, paragraphs 2-7 and 5-6 are to be completed to insure normal system operation.

**b. Channel Pushbutton Switches.**

(1) Disconnect and tag the leads to the various sections of the pushbutton switches.

(2) Remove the four nuts, lockwashers, and screws holding the frame to the panel, and remove the switch assembly from the rear of the panel.

(3) To replace the defective parts reverse steps (1) and (2) above.

**c. TLC-409 and TLC-503 Amplifier Modules.**

(1) To remove the plug-in units from their sockets, first remove the nut, lockwasher and machine screw fastening the module to the angle support brackets (fig. 1 or 2).

(2) Grasp the eyelet tabs used to attach to the mounting brackets with a pair of pliers or hooked tool and pull the unit straight out of its socket.

(3) To replace the plug-in units reverse steps (1) and (2) above.

**5-9. Adjustment Procedures**

**a. General.** The only adjustment involved in the intercom system is the gain adjustment on the modules, which are set to provide the desired output with a specified input. The VOLUME controls on the front panel of the intercom units provide local control over listening volume.

**b. Preamplifier TLC-508 Gain Adjustment (fig. FO-2 and FO-3).**

(1) Turn power ON-OFF switch on central or remote intercom to OFF.

(2) Connect an audio signal generator to the 50-ohm input at terminals TB1-5 and TB2-24 on the remote unit, or TB2 terminals 25 and 26 of the central intercom. These terminals correspond to pins 1 and 10 on the module.

(3) Loosen locknut on GAIN control on front panel of module, which is accessible from rear of both intercom units.

(4) Set signal generator for an output of 0.7 mV/rms 50  $\Omega$  at 1000 Hz. Connect an unterminated ac voltmeter across output TB2 terminals 20 and 27 of central intercom; or connect ac voltage across terminals TB1-7 and 8 of remote intercom, and clip a 600-ohm load termination across these terminals.

(5) Turn power switch on intercom to ON and adjust either intercom output by setting GAIN control for a nominal  $-6 \text{ dBm} \pm 0.1 \text{ dB}$  output (0.39V rms/600  $\Omega$ ), and tighten locknut.

**NOTE**

Gain across module amplifier test points J1 and J2 (if used) is 10 dB below the respective TB1 or TB2 output terminals.

(6) Turn OFF intercom. Remove test equipment, cables and connections, then turn intercom ON.

**c. Speaker Power Amplifier TLC-409 Gain Adjustment (fig. FO-2 and FO-3).**

(1) Turn power switch on central or remote intercom to OFF.

(2) Connect an audio signal generator to the 600-ohm input terminals TB1-1 and -2 on the remote unit, and on the central unit for AMPL-1. This corresponds to pins 1 and 2 on the module.

(3) Connect the prods of an ac voltmeter on monitor jacks J1 and J2 on the TLC-409 module, which is accessible from the rear of the intercom chassis.

(4) Loosen locknut on GAIN control on module front panel and set is fully clockwise, adjust audio signal generator for a  $-6 \text{ dBm}$  output (0.39V rms/600  $\Omega$ ) at 1000 Hz, and turn power switch of intercom to ON.

(5) Adjust GAIN control for a  $2V \pm 0.1V$  indication on ac voltmeter, and tighten locknut.

(6) Turn OFF intercom and remove test equipment, cables, and connections, then turn intercom ON.

**d. Line Power Amplifier TLC-409 Gain Adjustment, Central Intercom Only (fig. FO-2).**

(1) Turn power ON-OFF switch on central intercom unit to OFF.

(2) Connect an audio signal generator to the attenuator input TB2-20 and 27, and adjust for  $-6 \text{ dBm}$  (0.39V/600 $\Omega$ ) output at 1000 Hz on an ac voltmeter connected between monitor jacks J1 and J2 of the TLC-409 power amplifier.

(3) Connect a multimeter to TB1-7 and 8.

(4) Loosen the locknut on the module GAIN control, and turn the power ON-OFF switch to ON.

(5) Adjust GAIN control on TLC-409 power amplifier for a  $0.4V \text{ rms} \pm 0.5V \text{ rms}$  output, and tighten locknut.

(6) Turn central intercom power ON-OFF switch to OFF, and remove test equipment, cables, and connections, then turn the central intercom back ON.

**NOTE**

All adjustments are to be made with the TLC-409 or TLC-508 amplifier units plugged into the central or remote intercom units.

## CHAPTER 6

## SHIPMENT AND LIMITED STORAGE AND DEMOLITION TO PREVENT ENEMY USE

### 6-1. Repackaging

Repackaging of the equipment for shipment or limited storage normally will be performed at a repackaging facility or by a repackaging team. Should emergency packaging be required, select the materials from those listed in SB 38-100.

### 6-2. Authority for Demolition

Demolition of the equipment will be accomplished only upon order of the commander. Use the destruction procedures outlined in paragraph 6-3 to prevent further use of the equipment.

### 6-3. Methods of Destruction

Destruction of equipment, spare parts, and manuals to prevent capture or abandonment to the enemy is accomplished by using tools, equipment, and explosives normally available. Priority should be given to the destruction of all plug-in circuit cards. Cabling, connectors and hardware should then be destroyed as time permits.

*a. Smash.* Smash all printed circuit cards.

*b. Cut.* Cut all cables and wiring.

*c. Bend.* Bend panels, hardware, and the equipment assembly.

#### WARNING

Be extremely careful when handling explosives and incendiary devices. Use these items only when the need is urgent.

*d. Burn.* Burn printed circuit cards, wiring diagrams, and technical manuals.

*e. Explode.* Use explosives if necessary.

*f. Dispose.* Bury or scatter the destroyed parts in slit trenches or foxholes, or throw them into streams.

### 6-4. Reporting

Report all destruction of equipment in accordance with established priorities and through established command channels.

APPENDIX A

**REFERENCES**

---

The following publications contain information applicable to the operation and maintenance of the equipment.

- |                            |  |
|----------------------------|--|
| <p><b>DA Pam 310-4</b></p> | <p><b>Index of Technical Manuals, Technical Bulletins, Supply Manuals (Types 7, 8, and 9), Supply Bulletins, and Lubrication Orders.</b></p> |
| <p><b>DA Pam 310-7</b></p> | <p><b>US Army Equipment Index of Modification Work Orders.</b></p>   |
| <p><b>SB 38-100</b></p>    | <p><b>Preservation, Packaging, Packing and Marking Materials, Supplies and Equipment Used by the Army.</b></p>                               |
| <p><b>TB SIB 222</b></p>   | <p><b>Solder and Soldering.</b></p>  |
| <p><b>TB 746-10</b></p>    | <p><b>Field Instructions for Painting and Preserving Electronics Command Equipment.</b></p>  |
| <p><b>TM 38-750</b></p>    | <p><b>The Army Maintenance System (TAMMS).</b></p>   |
| <p><b>TM 740-90-1</b></p>  | <p><b>Administrative Storage of Equipment.</b></p>   |

## A P P E N D I X B

**BASIC ISSUE ITEMS LIST AND ITEMS TROOP INSTALLED OR AUTHORIZED  
LIST AND ORGANIZATIONAL, DIRECT SUPPORT, AND GENERAL  
SUPPORT MAINTENANCE REPAIR PARTS AND SPECIAL TOOLS LIST  
(INCLUDING DEPOT MAINTENANCE REPAIR PARTS AND SPECIAL TOOLS)**

---

Section I. **INTRODUCTION****B-1. Scope**

This appendix lists basic issue items, items troop installed or authorized, repair parts, and special tools required by the crew/operator for operation and required for the performance of organizational, direct support, general support, and depot maintenance of the LS-626/FSC and LS-627/FSC.

**B-2. General**

This Basic Issue Items, Items Troop, Installed or Authorized, Repair Parts, and Special Tools List is divided into the following sections:

**a. Basic Issue Items List—Section II. Not applicable.**

**b. Items Troop Installed or Authorized List—Section III. Not applicable.**

**c. Organizational Maintenance Repair Parts list—Sections IV and IX.** A list of repair parts authorized at the organizational level for the performance of maintenance. The list also includes parts which must be removed for the replacement of the authorized parts. Parts lists are listed in figure and item number sequence,

**d. Special Tools List—Sections V and X.** Not applicable.

**e. Repair Parts for Direct Support, General Support and Depot Maintenance—Section VI and XI.** A list of repair parts authorized at the direct support, general support, and depot levels for the performance of maintenance. The list also includes parts which must be removed for the replacement of the authorized parts. Parts lists are listed in figure and item number sequence.

**f. Special Tools List—Section VII and XII.** Not applicable.

**g. Federal Stock Number and Reference Number Index—Sections VIII and XIII.** A list, in ascending numerical sequence, of all Federal Stock numbers appearing in the listings, followed by a list, in alphabetic sequence, of all reference numbers appearing in the listings. Federal stock number and reference numbers are cross-referenced to each illustration figure and item number appearance.

**B-3. Explanation of Columns**

The following provides an explanation of columns found in the tabular listings.

*a Source, Maintenance, and Recoverability Codes (SMR).*

(1) Source code. Source codes are assigned to support item to indicate the manner of acquiring support items for maintenance, repair, or overhaul of end items. Source codes are entered in the first and second positions of the Uniform SMR Code Format as follows :

<i>Code</i>	<i>Definition</i>
PA-Item procured and stocked for anticipated or known usage.	
PB-Item procured and stocked for insurance purposes because essentiality dictates that a minimum quality be available in the supply systems.	
PC-Item procured and stocked and which otherwise would be coded PA except that it is deteriorative in nature.	
PD-Support item, excluding support equipment, procured for initial issue or outfitting and stocked only for subsequent or additional initial issue or outfittings. Not subject to automatic replenishment.	
PE-Support equipment procured and stocked for initial issue or outfitting to specified maintenance repair activities.	
PF-Support equipment which will not be stocked but which will be centrally procured on demand.	
PG-Item procured and stocked to provide for sustained	

<i>Code</i>	<i>Definition</i>
	support for the life of the equipment. It is applied to an item peculiar to the equipment which because of probable discontinuance of shutdown facilities would prove uneconomical to reproduce at a later time.
KD-	An item of depot overhaul/repair and not purchased separately. Depot Kit defined as a kit that provides items required at the time of overhaul or repair.
RF-AN	Item of a maintenance kit and not purchased separately. Maintenance kit defined as a kit that provides an item that can be replaced at organizational or intermediated levels of maintenance.
RB-	Item included in both a depot overhaul/repair kit and a maintenance kit.
MO-	Item to be manufactured or fabricated at organizational level.
MF-	Item to be manufactured or fabricated at direct support maintenance level.
MH-	Item to be manufactured or fabricated at general support maintenance level.
MD-	Item to be manufactured at depot maintenance level.
AO-	Item to be assembled at organization level.
AF-	Item to be assembled at direct support maintenance level
AH-	Item to be assembled at general support maintenance level.
AD-	Item to be assembled at depot maintenance level.
XA-	Item is not procured or stocked because the requirements for the item will result in the replacement of the next higher assembly.
XB-	Item is not procured or stocked. If not available through salvage, requisition.
XD-	Support item that is not stocked. When required, item will be procured through normal supply channels.

**NOTE**

Cannibalization or salvage may be used as a source of supply for any items source coded above except those coded XA, XD, and aircraft support items as restricted by AR 700-42.

(2) Maintenance code. Maintenance codes are assigned to indicate the levels of maintenance authorized to USE and REPAIR support items. The maintenance codes are entered in the third and fourth positions of the Uniform SMR Code Format as follows: USE (THIRD POSITION): The maintenance code entered in the third position indicates the lowest maintenance level authorized to remove, replace, and use the support item. The maintenance code entered in the third position indicates one of the following levels of maintenance.

<i>Code</i>	<i>Application/Explanation</i>
C-	Crew or operator maintenance performed within organizational maintenance.

<i>Code</i>	<i>Application/Explanation</i>
O-	Support item is removed, replaced, used at the organizational level.
I-	Support item is removed, replaced, used by the direct support element of intergrated direct support maintenance.
F-	Support item is removed, replaced, used at the direct support level.
H-	Support item is removed, replaced, and used at the general support level.
D-	Support items that are removed, replaced, used at depot, mobile depot, Specialized Repair Activity only.

**NOTE**

Codes "T" and "F" will be considered the same by direct support units.

**REPAIR (FOURTH POSITION):** The maintenance code entered in the fourth position indicates whether the item is to be repaired and identifies the lowest maintenance level with the capability to perform complete repair (i.e., all authorized maintenance functions). This position will contain one of the following maintenance codes:

<i>Code</i>	<i>Application/Explanation</i>
O-	The lowest maintenance level capable of complete repair of the support item is the organizational level.
F-	The lowest maintenance level capable of complete repair of the support item is direct support level.
H-	The lowest maintenance level capable of complete repair of the support item is general support level
D-	The lowest maintenance level capable of complete repair of the support item is the depot level, performed by Lexington Army Depot.
L-	Repair restricted to designated Specialized Repair Activity.
Z-	Nonrepairable. No repair is authorized.
D-	No repair is authorized. The item may be reconditioned by adjusting, lubricating, etc., at the w level. No parts or special tools are procured for the maintenance of this item.

(3) Recoverability code. Recoverability codes are assigned to support items to indicate the disposition action on unserviceable items. The recoverability code is entered in the fifth position of the Uniform SMR Code Format as follows:

<i>Code</i>	<i>Definition</i>
Z-	Non-repairable item. When unserviceable, condemn and dispose at the level indicated in the position three.
O-	Repairable item. When uneconomically repairable, condemn and dispose at organizational level.
F-	Repairable item. When uneconomically repairable, condemn and dispose at the direct support level.
H-	Repairable item. When uneconomically repairable, condemn and dispose at the general support level.

**2. Defects**

**B—Repairable Item.** When beyond lower level repair capability, return to depot. Condemnation and disposal not authorized below depot level.

**I—Repairable Item.** Repair, condemnation, and disposal not authorized below depot/Specialized Repair Activity level.

**A—Item** required special handling or condemnation procedures because of specific reasons (i.e., precious metal content, high dollar value, critical material or hazardous material). Refer to appropriate manual/directive for specific instructions.

**b. Federal Stock Number.** Indicates the Federal stock number assigned to the item and will be used for requisitioning purposes.

**c. Description.** Indicates the Federal item name and a minimum description required to identify the item. The last line indicates the reference number followed by the applicable Federal Supply Code for the Manufacturer (FSCM) in parentheses. The FSCM is used as an element in item identification to designate manufacturer or distributor or Government agency, etc., and is identified in SB 708-42.

**d. Unit of Measure (U/M).** Indicates the standard or basic quantity by which the listed item is used in performing the actual maintenance function. This measure is expressed by a two-character alphabetical abbreviation, e.g., ea, in, pr, etc., and is the basis used to indicate quantities and allowances in subsequent columns. When the unit of measure differs from the unit of issue, the lowest unit of issue that will satisfy required unit8 of measure will be requisitioned.

**e. Quantity Furnished with Equipment (Basic Issue Items Only).** Not applicable.

**f. Quantity Authorized (Item Troop Installed or Authorized Only).** Not applicable.

**g. Quantity Incorporated in unit.** Indicates the quantity of the item used in the breakout shown on the illustration figure, which is prepared for a functional group, subfunctional group, or an assembly.

**h. 15-Day Organizational Maintenance Allowances.**

(1) The repair parts indicated by an asterisk in the allowance column represent those authorized for use at the organizational category, and will be requisitioned on an "as required" basis, until stockage is based on demand in accordance with AR 710-2.

(2) Major Army commanders are authorized to approve reduction in the range of support

items authorized for use in units within their commands. Recommendations for increase in range of items authorized for use will be forwarded to Commander, US Army Electronics Command, ATTN: AMSEL-MA-C, Fort Monmouth, N. J. 07703.

**i. 30-Day DS/GS Maintenance Allowances.**

**NOTE**

**Allowances in GS column are for GS maintenance only.**

The repair parts indicated by asterisk entries in separate allowance columns for DS and GS represent those authorized for use at that category of maintenance to be requisitioned on an "as required" basis until stockage is based on demand in accordance with AR 710-2.

**j. 1-Year Allowances Per 100 Equipments/Contingency Planning Purposes.** Column intentionally -left blank.

**k. Depot Maintenance Allowance Per 100 Equipments.** This column indicates that the items identified with an asterisk are authorized to be requisitioned as required.

**l. Illustration.** This column is divided as follows:

(1) **Figure number.** Indicates the figure number of the illustration on which the item is shown.

(2) **Item number.** Indicates the callout number used to reference the item on the illustration.

**B-4. Special Information**

Not applicable.

**B-5. How to locate Repair Parts**

**a. When Federal stock number or reference number is unknown:**

(1) **First.** Find the illustration where the repair parts belongs.

(2) **Second.** Identify the repair parts on the illustration and note the illustration figure and item number of the repair part.

(3) **Third.** Using the Repair Parts Listing, find where the repair part belongs and locate the illustration figure and item number noted on the illustration.

**b. When Federal stock number or reference number is known:**

(1) *First.* Using the Index of Federal Stock Numbers and Reference Numbers find the pertinent Federal stock number or reference number. This index is in ascending FSN sequence followed by a list of reference numbers in ascending alphameric sequence, cross-referenced to the illustration figure number and item number.

(2) *Second.* Using the Repair Parts Listing,

find the repair part and the illustration figure number and item number referenced in the Index of Federal Stock Numbers and Reference Numbers.

**B-6. Abbreviations**

Not applicable.



SECTION IV

TM 11-5830-255-14

ORGANIZATIONAL MAINTENANCE REPAIR PARTS LIST

LS-626/FSC

FEDERAL STOCK NUMBER	DESCRIPTION	USE ON CODE	MFR. NUMBER (MFR. PART NO.)	MFR. CODE	QTY. INCL. IN KIT	IS THIS ORGANIZATIONAL MAINT. A.M.				ILLUSTRATIONS	
						1	2	3	4	FIGURE NUMBER	PWP. / ITEM NUMBER
15830-281-3845	INTERCONNECTION 798100 (18633)									1	1
<b>PAGE</b> 15945-189-4746	RELAY, ARMATURE PD1400A22 (04773)	EA			1	*	*	*	*	1	9
<b>PAGE</b> 15930-905-4754	FUSE, CARTRIDGE ONA1 (71400)	EA			1	*	*	*	*	1	12
<b>PAGE</b>	LAMP, INCANDESCENT OL8013 (31869)	EA			2	*	*	*	*	1	13
<b>PAGE</b>	AMPLIFIER, VARIABLE FREQUENCY TLC409 (64294)	EA			1	*	*	*	*	1	22
<b>PAGE</b>	AMPLIFIER, VARIABLE FREQUENCY TLC503 (64294)	EA			1	*	*	*	*	1	23

SECTION VI

REPAIR PARTS FOR DIRECT SUPPORT, GENERAL SUPPORT AND DEPT. MAINTENANCE

LS-626/78C

FEDERAL STOCK NUMBER	DESCRIPTION	USE OR CODE	UNIT	30 DAY MAINT. ALW.						ILLUSTRATIONS		
				1-30		31-60		61-90			FIGURE NUMBER	REF. / ITEM NUMBER
				1-15	16-30	31-45	46-60	61-75	76-90			
5830-281-3845	INTERCONNECTION LS-626/FSC 798100 (18633)									1	1	
PAHZZ 5940-983-6071	TERMINAL BOARD 40TB10 (81349)	EA	1			*	*	*		*	1	2
PAHZZ 9905-877-1100	STRIP, MARKER MS10-140Y (71785)	EA	1			*	*	*		*	1	3
PAHZZ 5961-880-2938	SEMICONDUCTOR DEVICE, DIODE IN4003 (04713)	EA	2			*	*	*		*	1	4
PAHZZ 5905-141-0592	RESISTOR, FIXED, COMPOSITION RCR20G122JS (81349)	EA	1			*	*	*		*	1	5
PAHZZ 5940-082-4662	TERMINAL WARD 1402-35 (71279)	EA	1			*	*	*		*	1	6
PAHZZ 5940-156-7344	TERMINAL, LUG A3250-12 (76665)	EA	2			*	*	*		*	1	7
PAHZZ 6350-239-5581	BUZZER SC24 (37942)	EA	1			*	*	*		*	1	8
PAOZZ 5945-189-4746	RELAY, ARMATURE PD1400A22 (04773)	EA	1	*	*	*	*	*		*	1	9
PAHZZ 5935-180-3950	SOCKET, RELAY PP50523-2 (04773)	EA	1			*	*	*		*	1	10
PAHZZ 5920-903-4157	FUSEHOLDER HLD (71400)	EA	1			*	*	*		*	1	11
PAOZZ 5920-905-4754	FUSE CARTRIDGE GBA1 (71400)	EA	1	*	*	*	*	*		*	1	12
PAOZZ	LAMP, INCANDESCENT OL6032 (31869)	EA	2	*	*	*	*	*		*	1	13
PAHZZ 5930-224-8164	PUSHBUTTON ASSEMBLY 67051K512 (82389)	EA	1			*	*	*		*	1	14
PAHZZ 5930-227-5080	SWITCH, PUSH 8X03-3 (82389)	EA	1			*	*	*		*	1	15
PAHZZ 5965-220-6900	LOUDSPEAKER, PERMANENT MAGNET 30A05Z8 (74199)	EA	1			*	*	*		*	1	16

SECTION VI

REPAIR PARTS FOR DIRECT SUPPORT, GENERAL SUPPORT AND DEPOT MAINTENANCE LS-636/280

(1) PART NUMBER	(2) FEDERAL STOCK NUMBER	(3) DESCRIPTION	(4) USE OR CODE	(5) QTY. REQ. BY LINE	(6) 30 DAY MAINT. ALW.						(7) 1 YR. ALW. PER US ARMY COMBAT PL.	(8) DEPOT MAINT. ALW. PER V. 3 SCHED.	(9) ILLUSTRATIONS	
					(a)			(b)					(a) FIGURE NUMBER	(b) REF. / ITEM NUMBER
					1-30	31-60	61-90	1-30	31-60	61-90				
PAHZZ	5930-655-1514	SWITCH, TOGGLE 8801K22 (27193)	EA	1				*	*	*		*	1	17
PAHZZ	5930-548-5533	SWITCH, ROTARY 2003 (82389)	EA	1				*	*	*		*	1	18
PAHZZ	5355-218-6434	KNOB 2236 (83330)	EA	1				*	*	*		*	1	19
PAHZZ	5355-218-6422	KNOB 2273 (83330)	EA	1				*	*	*		*	1	20
PAHZZ	5905-957-2247	ATTENUATOR, VARIABLE L8A (37942)	EA	1				*	*	*		*	1	21
PAHZZ	5310-680-6627	NUT, PLAIN, HEXAGON MS25082-1 (96906)	EA	20				*	*	*		*		
PAHZZ	5305-984-4983	SCREW, MACHINE MS24584-23 (96906)	EA	8				*	*	*		*		
PAHZZ	5310-045-4007	WASHER, LOCK MS35338-41 (96906)	EA	20				*	*	*		*		
XBHZZ		BRACKET, ANGLE 619 (91833)	EA	2										
XBHZZ		BRACKET, DOUBLE ANGLE 798104 (18633)	EA	1										
XBHZZ		CHASSIS, ELECTRICAL EQUIPMENT TLC902A (64294)	EA	1										
PAHZZ	5310-934-9757	NUT, PLAIN, HEXAGON MS35649-282 (96906)	EA	4				*	*	*		*		
PAHZZ	5305-638-3305	SCREW, MACHINE MS35223-4 (96906)	EA	4				*	*	*		*		
XBHZZ		WASHER, LOCK MS35337-42 (96906)	EA	4										
XBHZZ		CHASSIS, ELECTRICAL EQUIPMENT 798103-1 (18633)	EA	1										
PAHZZ	5340-257-0039	CLAMP, LOOP 127085 (77885)	EA	2				*	*	*		*		
PAHZZ	5305-207-0763	SCREW, MACHINE MA35223-28 (96906)	EA	2				*	*	*		*		

SECTION VI

REPAIR PARTS FOR DIRECT SUPPORT, GENERAL SUPPORT AND DEBIT MAINTENANCE 15-636/76C

FEDERAL STOCK NUMBER	DESCRIPTION	USE OR CODE	QTY. INCL. IN UNIT	STANDARD, ALN.						QTY. INCL. IN UNIT	QTY. INCL. IN UNIT	ILLUSTRATIONS	
				01-01		01-02		01-03				FIGURE NUMBER	REF. / ITEM NUMBER
				01-01	01-02	01-03	01-04	01-05	01-06				
5310-579-0079	WASHER, LOCK MS35333-37 (96906)	EA	2				*	*	*				
5307-191-8799	SCREW, SELF-LOCKING FM632-8C (46384)	EA	10				*	*	*				
5310-616-6822	WASHER, FLAT NAS620-6L (80205)	EA	8				*	*	*				
X8HZZ	PANEL, MOUNTING 798102 (18633)	EA	1										
W8HZZ	PLATE, DESIGNATION TT501 (82389)	EA	1										
X8HZZ	SCREEN, METAL 798105 (18633)	EA	1										
5340-917-8296	SUPPORT, TIE HARNESS TC105A (59730)	EA	3				*	*	*				
5305-543-2188	SCREW, MACHINE MS35223-32 (96906)	EA	8				*	*	*				
5340-726-2035	SPACER, SLEEVE 2100 (83330)	EA	4				*	*	*				
PAGEZ	AMPLIFIER, VARIABLE FREQUENCY TLC409 (64294)	EA	1				*	*	*			1	22
PAGEZ	AMPLIFIER, VARIABLE FREQUENCY TLC503 (64294)	EA	1				*	*	*			1	23

SECTION VIII

FEDERAL STOCK NUMBER AND REFERENCE NUMBER INDEX

LS-636/TSC

FEDERAL STOCK NUMBER

5355-218-6422  
 5355-218-6434  
 5830-281-3845  
 5905-141-0592  
 5905-957-2247  
 5920-903-4157  
 5920-905-4754  
 5930-224-8164  
 5930-227-5080  
 5930-548-5533  
 5930-655-1514  
 5935-180-3950  
 5940-082-4662  
 5940-156-7344  
 5940-983-6071  
 5945-189-4746  
 5961-880-2938  
 5965-220-6900  
 6350-239-5581  
 9905-877-1100

FIGURE  
NUMBER

1  
1  
1  
1  
1  
1  
1  
1  
1  
1  
1  
1  
1  
1  
1  
1  
1  
1  
1  
1  
1  
1  
1  
1

ITEM  
NUMBER

20  
19  
1  
5  
21  
11  
12  
14  
15  
18  
17  
10  
6  
7  
2  
9  
4  
16  
8  
3

SECTION VIII

FEDERAL STOCK NUMBER AND REFERENCE NUMBER INDEX

LS-626/FSC

MANUFACTURER PART NUMBER	FED MFR CODE	FIGURE NUMBER	ITEM NUMBER
A3250-12	76665	1	7
BX03-3	82389	1	15
GBA1	71400	1	12
HLD	71400	1	11
L 8 A	37942	1	21
MS10-140Y	71785	1	3
PD1400A22	04773	1	9
PP50523-2	04773	1	10
RCR20G122JS	81349	1	5
SC24	37942	1	8
TLC409	64294	1	22
TLC503	64294	1	23
OL6032	31869	1	13
1N4003	04713	1	4
1402-35	71279	1	6
2003	82389	1	18
2236	83330	1	19
2273	83330	1	20
30A05Z8	74199	1	16
40TB10	81349	1	2
67051K512	82389	1	14
798100	18633	1	1
8801K22	27193	1	17

## SECTION IX

TM 11-5830-255-14  
ORGANIZATIONAL MAINTENANCE REPAIR PARTS LIST

SOURCE CODE MAINT CODE REC. CODE	FEDERAL STOCK NUMBER	DESCRIPTION  REF. NUMBER MFR. CODE (MFR. PART NO.)	USE ON CODE	(4) UNIT OF MEASURE	(5) QTY. INCL. IN UNIT	(6) 15 DAY OPERATIONAL MAINT. ALLOW.				(7) ILLUSTRATIONS	
						(a)	(b)	(c)	(d)	(a)	(b)
						1-4	5	6-8	9-12	FIGURE NUMBER	REF. / ITEM NUMBER
	5830-285-5330	INTERCONNECTION LS-627/FSC 798101 (18633)								2	1
<b>PAQZZ</b>	5820-905-4759	FUSE, CARTRIDGE GBA2 (71400)		EA	1	*	*	*	*	2	13
<b>PAQZZ</b>	5310-680-6627	NUT, PLAIN, HEXAGON M S 2 5 0 8 2 - 1		EA	18	*	*	*	*		
<b>PAQZZ</b>	5305-984-4984	SCREW, MACHINE MS35206-227 (96906)		EA	4	*	*	*	*		
<b>PAQZZ</b>	5310-045-4007	WASHER, LOCK MS35338-41 (96906)		EA	14	*	*	*	*		
<b>PAQZZ</b>		AMPLIFIER, VARIABLE FREQUENCY TLC409 (64294)		EA	2	*	*	*	*	2	24
<b>PAQZZ</b>		AMPLIFIER, VARIABLE FREQUENCY TLC503 (64294)		EA	1	*	*	*	*	2	25

SECTION XI

TM 11-5830-255-14

REPAIR PARTS FOR DIRECT SUPPORT, GENERAL SUPPORT AND DEPOT MAINTENANCE

SOURCE CODE CORE MAINT. CLASS CHRG REPL. CODE	FEDERAL STOCK NUMBER	DESCRIPTION	USE ON CODE	UNIT OF MEASURE	QTY. INCL. IN UNIT	30 DAY MAINT. ALW.						1 YR. ALW. PER 100 EQUIP. CONTRACT PL.	DEPOT MAINT. ALW. PER 100 EQUIP.	(18) ILLUSTRATIONS	
						DB			DS					FIGURE NUMBER	REF. / ITEM NUMBER
						1-99	100-199	200-299	1-99	100-199	200-299				
						DB	DS	DB	DS	DB	DS				
	5830-285-5330	INTERCOMMSTATION LS-627/FSC 798101 (18633)											2	1	
PAHZZ	3961-880-2938	SEMICONDUCTOR DEVICE, DIODE 1N4003 (04713)	EA	20				*	*	*			*	2	2
PAHZZ	5940-082-4662	TERMINAL BOARD 1402-35 (71279)	EA	1				*	*	*			*	2	3
PAHZZ	5935-062-1776	CONNECTOR, PLUG, ELECTRICAL 57-40500 (02660)	EA	2				*	*	*			*	2	4
PAHZZ	5940-983-6073	TERMINAL BOARD 12-140Y (71785)	EA	1				*	*	*			*	2	5
PAHZZ	5905-141-0592	RESISTOR, FIXED, COMPOSITION RCR20G122JS (81349)	EA	1				*	*	*			*	2	6
PAHZZ	6350-239-5581	BUZZER SC24 (37942)	EA	1				*	*	*			*	2	7
PAHZZ	5935-180-3950	SOCKET, RELAY PP50523-2 (04773)	EA	1				*	*	*			*	2	8
PAHZZ	5945-189-4746	RELAY, ARMATURE PD1400A22 (04773)	EA	1				*	*	*			*	2	9
PAHZZ	5920-903-415	FUSE HOLDER HLD (71400)	EA	1				*	*	*			*	2	10
PAHZZ		LAMP, INCANDESCENT OL6032 (31869)	EA	20				*	*	*			*	2	11
PAHZZ		PUSHBUTTON ASSEMBLY 798110 (18633)	EA	2				*	*	*			*	2	12
PAOZZ	5920-905-4759	FUSE CARTRIDGE GBA2 (71400)	EA	1	*	*	*	*	*	*			*	2	13
PAHZZ	5930-655-1514	SWITCH, TOGGLE 8801K22 (27193)	EA	1				*	*	*			*	2	14
PAHZZ	5905-957-2247	ATTENUATOR, VARIABLE I.84 (37942)	EA	1				*	*	*			*	2	15
PAHZZ	5355-218-6422	KNOB 2273 (83330)	EA	1				*	*	*			*	2	16



PART NUMBER	QUANTITY	DESCRIPTION	UNIT OF MEASURE	MATERIAL CODE	CAGE CODE						PART NUMBER	PART ITEM NUMBER
					1	2	3	4	5	6		
PAHZZ	5355-218-6434	KNOB 2236 (83330)					*	*	*		2	17
PAHZZ	5930-548-5533	SWITCH, ROTARY 2003 (82389)					*	*	*		2	18
PAHZZ	5905-424-9636	LOUDSPEAKER, PERMANENT MAGNET 4A1Z8 (74199)					*	*	*		2	19
PAHZZ	5930-227-5080	SWITCH, PUSH 3x03-3 (82389)					*	*	*		2	20
PAHZZ	5905-141-0595	RESISTOR, FIXED, COMPOSITION RCR20G472JS (81349)					*	*	*		2	21
PAHZZ	5905-141-0723	RESISTOR, FIXED, COMPOSITION RCR20G621JS (81349)					*	*	*		2	22
PAHZZ	5905-153-4354	RESISTOR, FIXED, COMPOSITION RCR42G100JS (81349)					*	*	*		2	23
PAOZZ	5310-680-6627	HUT, PLAIN, HEXAGON MS25082-1 (96906)				*	*	*	*	*		
PAOZZ	5305-984-4984	SCREW, MACHINE MS35206-227 (96906)				*	*	*	*	*		
PAOZZ	5310-045-4007	WASHER, LOCK MS35338-41 (96906)				*	*	*	*	*		
PAHZZ	5310-934-9739	NUT, PLAIN, HEXAGON MS35649-242 (96906)				*	*	*	*	*		
PAHZZ	5305-889-2997	SCREW, MACHINE MS35206-215 (96906)				*	*	*	*	*		
PAHZZ	5310-551-7770	WASHER, LOCK MS35337-40 (96906)				*	*	*	*	*		
XBHZZ		CHASSIS, ELECTRICAL EQUIPMENT 798103-2 (18633)										
PAHZZ	5305-984-4988	SCREW, MACHINE MS35206-228 (96906)				*	*	*	*	*		
PAHZZ	5310-599-0079	WASHER, LOCK MS35333-37 (96906)				*	*	*	*	*		
XBHZZ		CHASSIS, ELECTRICAL EQUIPMENT 798111 (18633)										

SECTION XI

REPAIR PARTS FOR DIRECT SUPPORT, GENERAL SUPPORT AND DEPOT MAINTENANCE 1S-1

SOURCE CODE MAINT. CODE REQ. CODE	FEDERAL STOCK NUMBER	DESCRIPTION REF. NUMBER MFR. CODE (MFR. PART NO.)	USE ON CODE	QTY. INCL. IN UNIT	30 DAY MAINT. ALW.						1 YR. ALW. PER 100 EQUIP. CONTRIB. P/L	DEPOT MAINT. ALW. PER 100 EQUIP.	(16) ILLUSTRATIONS		
					(6)			(7)					(a)	(b)	
					(1)	(2)	(3)	(4)	(5)	(6)					(7)
PAHZZ	5305-984-4982	SCREW, MACHINE MS35206-225 (96906)	EA	4				*	*	*					
XBHZZ		PANEL, MOUNTING 798106 (18633)	EA	1											
PAHZZ	5307-191-8799	SCREW, SELF-LOCKING FH632-8C (46384)	EA	6				*	*	*					
MMHZZ		PLATE, DESIGNATION 798109 (18633)	EA	2											
XBHZZ		SCREEN, METAL 798107 (18633)	EA	1											
XBHZZ		STRIP, DESIGNATION MS12-140Y (71785)	EA	1											
PAHZZ	5305-558-7361	SCREW, MACHINE MS35233-42 (96906)	EA	4				*	*	*					
PAHZZ	5305-984-4980	SCREW, MACHINE MS35206-223 (96906)	EA	6				*	*	*					
PAHZZ	5365-470-3237	SPACER, SLEEVE 2344 (83330)	EA	6				*	*	*					
PAHZZ	5310-193-7577	WASHER, LOCK MS35333-36 (96906)	EA	6				*	*	*					
PAQZZ		AMPLIFIER, VARIABLE FREQUENCY TL409 (64294)	EA	2				*	*	*	*	2	24		
PAQZZ		AMPLIFIER, VARIABLE FREQUENCY TLC503 (64294)	EA	1				*	*	*	*	2	25		

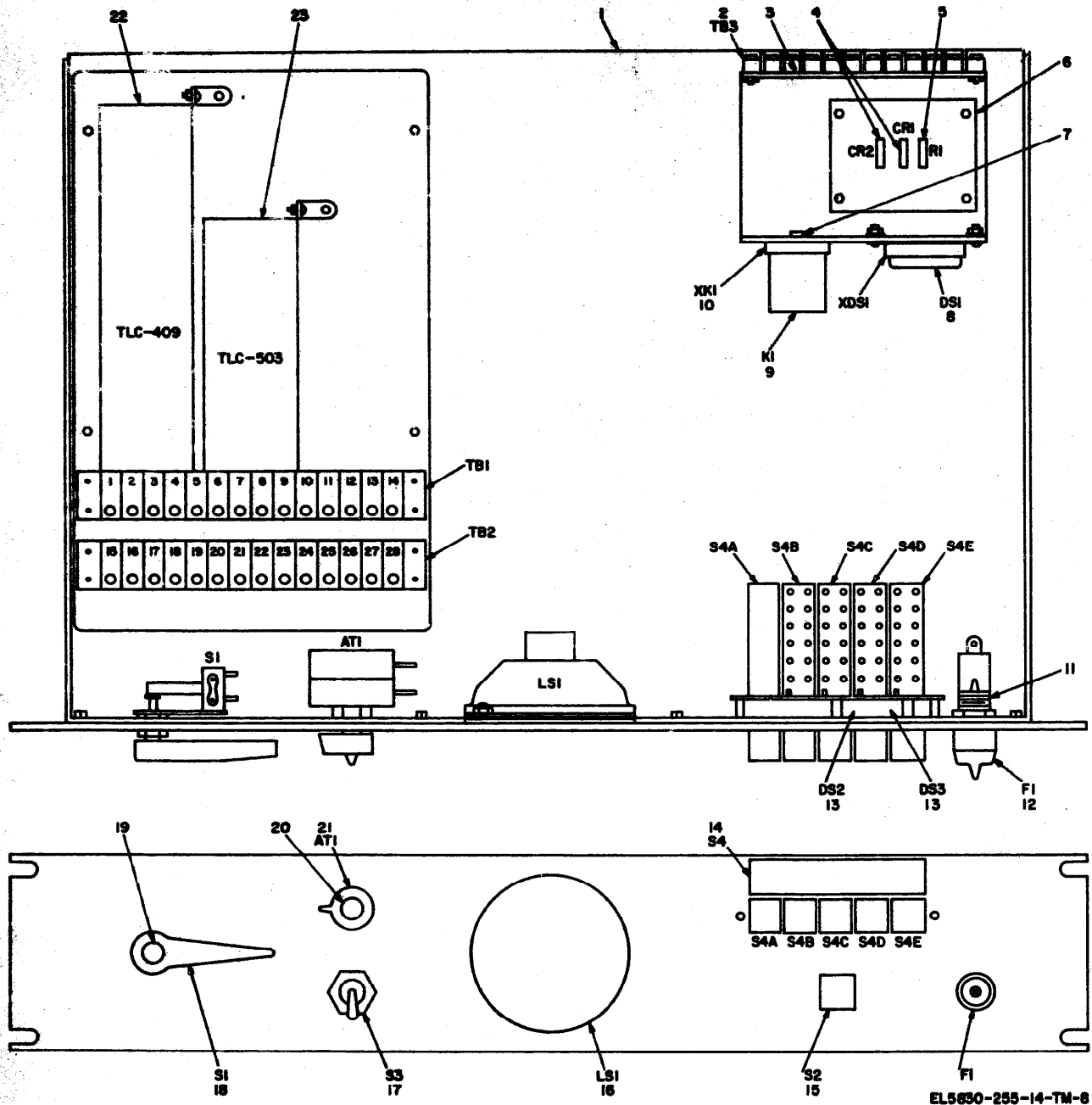

Figure 1. Remote intercom, parts location diagram.

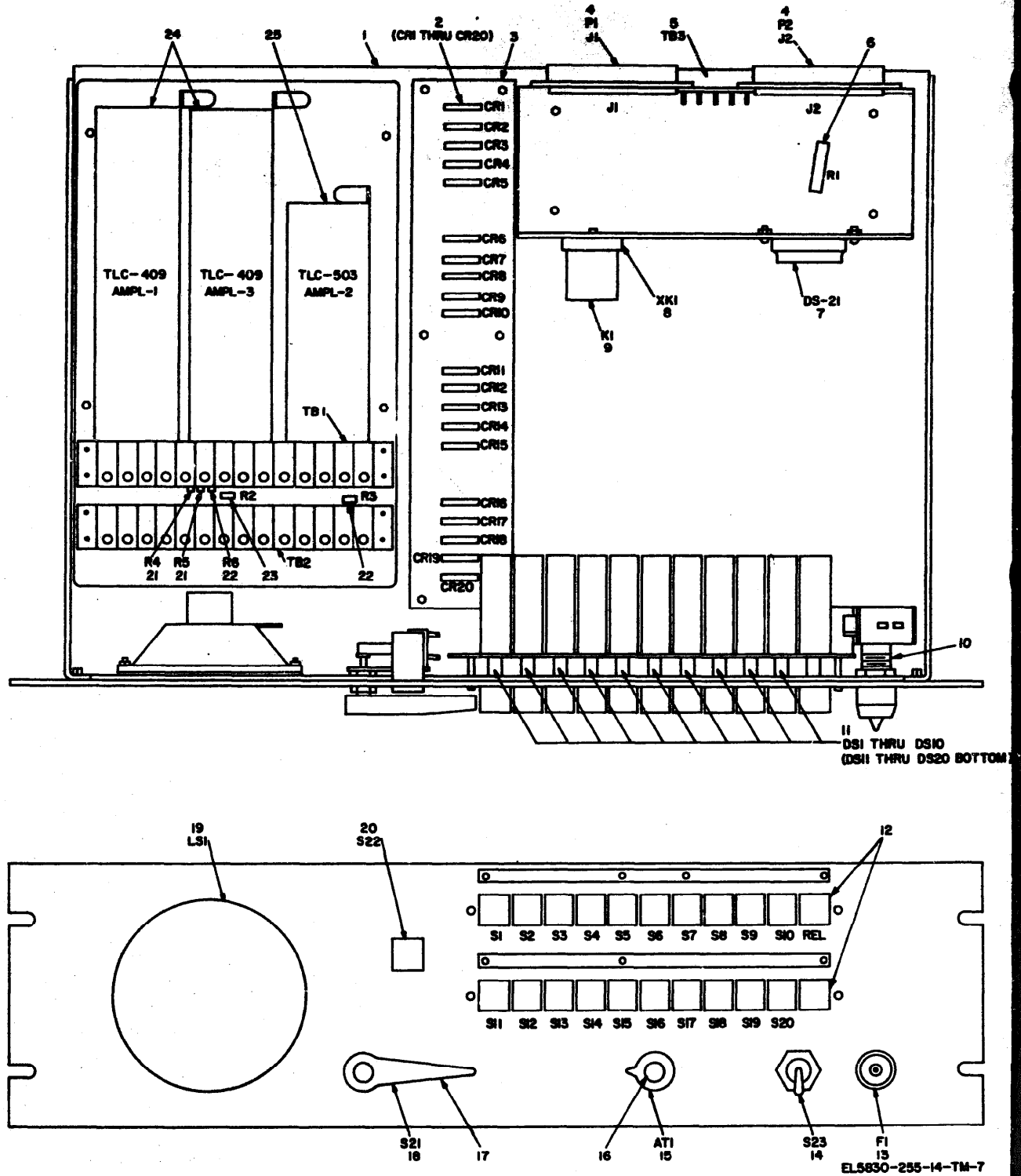

Figure 2. Central intercom, parts location diagram.

SECTION XIII

FEDERAL STOCK NUMBER AND REFERENCE NUMBER INDEX

FEDERAL STOCK NUMBER

FEDERAL STOCK NUMBER	FIGURE NUMBER	ITEM NUMBER
5355-218-6422	2	16
5355-218-6434	2	17
5830-285-5330	2	1
5905-141-0592	2	6
5905-141-0595	2	21
5905-141-0723	2	22
5905-153-4354	2	23
5905-957-2247	2	15
5920-903-4157	2	10
5920-905-4759	2	13
5930-227-5080	2	20
5930-548-5533	2	18
5930-655-1514	2	14
5935-062-1776	2	4
5935-180-3950	2	8
5940-082-4662	2	3
5940-983-6073	2	5
5945-189-4746	2	9
5961-880-2938	2	2
5965-424-9636	2	19
6350-239-5581	2	7

## SECTION XIII

TM 11-5830-255-14  
FEDERAL STOCK NUMBER AND REFERENCE NUMBER INDEX

LS-627/FSC

MANUFACTURER PART NUMBER	FED MFR CODE	FIGURE NUMBER	ITEM NUMBER
BK03-3	82389	2	20
GBA2	71400	2	13
HLD	71400	2	10
LBA	37942	2	15
PD1400A22	04773	2	9
PP50523-2	04773	2	8
RCR20G122JS	81349	2	6
RCR20G472JS	81349	2	21
RCR20G621JS	81349	2	22
RCR42G100JS	81349	2	23
SC24	37942	2	7
TLC409	64294	2	24
TLC503	64294	2	25
OL6032	31869	2	11
1N4003	04713	2	2
12-140Y	71785	2	5
1402-35	71279	2	3
2003	82389	2	18
2236	83330	2	17
2273	83330	2	16
4A128	74199	2	19
57-40500	02660	2	4
798101	18633	2	1
798110	18633	2	12
8801K22	27193	2	14

## APPENDIX C

## MAINTENANCE ALLOCATION

Section I. **INTRODUCTION****C-1. General**

This appendix provides a summary of the maintenance operations covered in the equipment literature. It authorizes categories of maintenance for specific maintenance functions on repairable items and components and the tools and equipment required to perform each function. This appendix may be used as (an aid in planning maintenance operations.

**C-2. Maintenance Functions**

Maintenance functions will be limited to and defined as follows :

*a. Inspect.* To determine serviceability of an item by comparing its physical, mechanical, and electrical characteristics with established standards.

*b. Test.* To verify serviceability and to detect incipient electrical or mechanical failure by use of special equipment such as gages, meters, etc. This is accomplished with external test equipment and does not include operation of the equipment and operator type tests using internal meters or indicating devices.

*c. Service.* To clean, to preserve, to charge, and to add fuel, lubricants, cooling agents, and air. If it is desired that elements, such as painting and lubricating, be defined separately, they may be so listed.

*d. Adjust.* To rectify to the extent necessary to bring into proper operating range.

*e. Align.* To adjust two or more components or assemblies of an electrical or mechanical system so that their functions are properly synchronized. This does not include setting the frequency control knob of radio receivers or transmitters to the desired frequency.

*f. Calibrate.* To determine the corrections to be made in the readings of instruments or test

equipment used in precise measurement. Consists of the comparison of two instruments, one of which is a certified standard of known accuracy, to detect and adjust any discrepancy in the accuracy of the instrument being compared with the certified standard.

*g. Install.* To set up for use in an operational environment such as an encampment, site, or vehicle.

*h. Replace.* To replace unserviceable items with serviceable like item.

*i. Repair.* To restore an item to serviceable condition through correction of a specific failure of unserviceable condition. This function includes, but is not limited to welding, grinding, riveting, straightening, and replacement of parts other than the trial and error replacement of running spare type items such as fuses, lamps, or electron tubes.

*j. Overhaul.* Normally, the highest degree of maintenance performed by the Army in order to minimize time work in process is consistent with quality and economy of operation. It consists of that maintenance necessary to restore an item to completely serviceable condition as prescribed by maintenance standards in technical publications for each item of equipment. Overhaul normally does not return an item to like new, zero mileage, or zero hour condition.

*k. Rebuild.* The highest degree of materiel maintenance. It consists of restoring equipment as nearly as possible to new condition in accordance with original manufacturing standards. Rebuild is performed only when required by operational considerations or other paramount factors and then only at the depot maintenance category. Rebuild reduces to zero the hours or miles the equipment, or component thereof, has been in use.

*l. Symbols.* The uppercase letter placed in the

appropriate column indicates the lowest level at which that particular maintenance function is to be performed.

**C-3. Explanation of Format**

*a. Column 1, Group Number.* Column 1 lists group numbers, the purpose of which is to identify components, assemblies, subassemblies and modules with the next higher assembly.

*b. Column 2, Functional Group.* column 2 lists the noun names of components, assemblies, subassemblies and modules on which maintenance is authorized.

*c. Column 8, Maintenance Fun&mu.* Column 3 lists the maintenance category at which performance of the specific maintenance function is authorized. Authorization to perform a function at any category also includes authorization to perform that function at higher categories. The codes used represent the various maintenance categories as follows :

<i>Code</i>	<i>Maintenance category</i>
C . . . . .	Operator/Crew
O . . . . .	Organizational Maintenance
F - - - - -	Direct Support Maintenance
H . . . . .	General Support Maintenance
D . . . . .	Depot Maintenance

*d. Column 4, Tools and Test Equipment.* Col-

**umn 4 specifies, by code, those tools and test equipment required to perform the designated function. The numbers appearing in this column refer to specific tools and test equipment which are identified in Table I.**

***e. Column 5, Remarks.* Self-explanatory.**

**C-4. Explanation of Format of Table 1, Tool and Test Equipment Requirements**

The column in Table I, Tool and Test Equipment Requirements are as follows:

*a. Tools and Equipment.* The numbers in this column coincide with the numbers wed in the tools and equipment column of the applicable tool for the maintenance function.

*b. Maintenance Category.* The codes in this column indicate the maintenance category normally allocated the facility.

*c. Nomenclature.* This column lists tools, test, and maintenance equipment required to perform the maintenance functions.

*d. Federal Stock Number.* This column lists the Federal stock number of the specific tool or test equipment.

*e. Tool Number.* Not used.



SECTION II. MAINTENANCE ALLOCATION CHART

LS-626/FSC

MAINTENANCE ALLOCATION CHART													
GROUP NUMBER	COMPONENT ASSEMBLY NOMENCLATURE	MAINTENANCE FUNCTIONS										TOOLS AND EQUIPMENT	REMARKS
		INSPECT	TEST	SERVICE	ADJUST	ALIGN	CALIBRATE	INSTALL	REPLACE	REPAIR	OVERHAUL		
	INTERCOMMUNICATION STATION LS-626/FSC EFE LABORATORIES INC. 798100		0									1 thru 4 1 thru 4 2,3,4 4	See Note 1 for all (F) level maintenance Replace fuse, lamps, relay K1, and amplifier modules
NOTE 1: Direct Support (F) level maintenance operations for fixed plant equipment located OCONUS, will be performed by Off-Site (Area Maint. and Supply Facility, AMSF) personnel.													

ESD-PM 97-46

TM 11-56830-255-114

TABLE I. TOOL AND TEST EQUIPMENT REQUIREMENTS

LS-626/FSC

TOOL AND TEST EQUIPMENT REQUIREMENTS					
TOOLS AND EQUIPMENT	MAINTENANCE CATEGORY	NOMENCLATURE		FEDERAL STOCK NUMBER	TOOL NUMBER
		AVAILABLE ON SITE	MILITARY EQUIVALENT		
		LS-626/FSC (CONT'D)			
1	O,F	MULTIMETER	AN/USM-210	6625-019-0815	
2	O,F,H	TEST SET., TELEPHONE/HP 3550B	AN/USM-181/U	6625-740-0344	
3	O,F	CABLE, TEST (2 EA. REQUIRED)	POMONA 2BB-AL30	6625-866-4509	
4	O,F	TOOL KIT, ELECTRONIC EQUIPMENT	TK-105/G	5180-610-8177	

MAINTENANCE ALLOCATION CHART															
GROUP NUMBER	COMPONENT ASSEMBLY NOMENCLATURE	MAINTENANCE FUNCTIONS										TOOLS AND EQUIPMENT	REMARKS		
		INSPECT	TEST	SERVICE	ADJUST	ALIGN	CALIBRATE	INSTALL	REPLACE	REPAIR	OVERHAUL			REBUILD	
	INTERCOMMUNICATION STATION LS-627/F8C EFE LABORATORIES, INC. 798101		O F											1 thru 4 1 thru 4 2, 3, 4 4 4	See Note 1 for all (F) level maintenance  Replace fuse, lamps, relay K1, and amplifier modules

NOTE 1:  
Direct Support (F) level maintenance operations for fixed plant equipment located OCONUS, will be performed by Off-Site (Area Maint. and Supply Facility, AMSF) personnel.

AMSL, 48 Form 1 Jan 66

4231 Obsolete edition of 1 Feb 66, which is obsolete

ESC-FM 97-66

TM 11-5830-255-14

TABLE I. TOOL AND TEST EQUIPMENT REQUIREMENTS

LS-627/FSC

TOOL AND TEST EQUIPMENT REQUIREMENTS						
TOLLS AND EQUIPMENT	MAINTENANCE CATEGORY	AVAILABLE ON SITE	NOMENCLATURE MILITARY EQUIVALENT	FEDERAL STOCK NUMBER	TOOL NUMBER	
		LS-627/FSC (CONT'D)				
1	O,F	MULTIMETER	AN/USM-210	6625-019-0815		
2	O,F,B	TESTS SET, TELEPHONE/HP 3550B	AN/USM-181/U	6625-740-0344		
3	O,F	CABLE, TEST (2 EA, REQUIRED)	POMONA 2BB-AL-30	6625-866-4509		
4	O,F	TOOL KIT, ELECTRONIC EQUIPMENT	TK-105/G	5180-610-8177		

ANSI Z39-18 Form 6013 (Supersedes edition of 1 Jan 65, which is obsolete)  
1 Jan 66

ESC-FM 98-66

**By Order of the Secretary of the Army:**

**CREIGHTON W. ABRAMS**  
*General, United States Army*  
*Chief of Staff*

**Official:**

**VERNE L. BOWERS**  
*Major General, United States Army*  
*The Adjutant General*

**DISTRIBUTION:**

*Action Army:*

USASA (2)  
 CNGB (1)  
 ACMC-E (2)  
 USAMB (10)  
 TRADOC (1)  
 ABADCOM (1)  
 OS Maj Comd (2) except  
   USAREUR (10)  
 AMC (1)  
 HISA (ECOM) (18)  
 USAGDCEC (8)  
 USACG (10)  
 USACG-PAC (1)  
 U S A C C - E U R ( 5 0 )  
 USACC-SO (2)  
 USACC-CONUS (5)  
 USMC-EUR Sig Spt Gp #4 (2)  
 USACC-EUR Sig Gp #22 (2)  
 USAC-EUR Sig Gp #106 (2)  
 USACC-EUR Sig Cen (2)  
 USMCC-EUR Sig Facility (2)

USACC-EUR Sig Op Bn (2),  
 USACC-EUR Sig Spt Agcy (2)  
 7th USA (6)  
 7th Sig Bde USACC-EUR (2)  
 SAAD (10)  
 TOAD (10)  
 LBAD (6)  
 Gen Dep (Eur) (2) except  
   Pirmasens (10)  
 Sig Sec, Gen Dep (Eur) (2)  
 Sig Dep (Eur) (2)  
 USAINTS (8)  
 MAAG (Eur) (1)  
 USARMIS (Eur) (1)  
 Units org under fol TOE:-1 ea.  
 if-97  
 11-98  
 11-117  
 11-127  
 11-158  
 11-500(AA-AC)

*ARNG & USAR:* None.

For explanation of abbreviations used, see AR. 310-50.

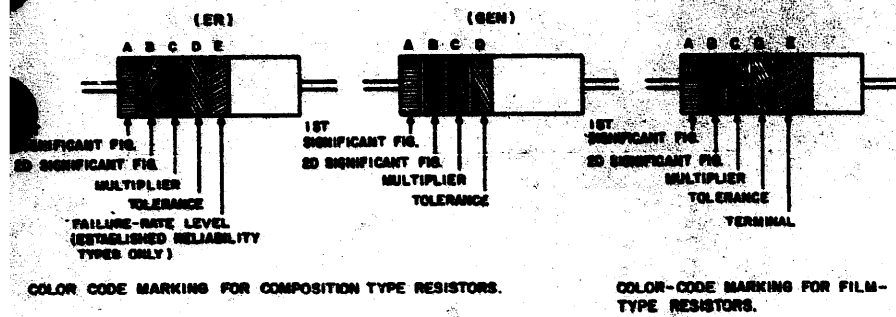

TABLE 1  
COLOR CODE FOR COMPOSITION TYPE AND FILM TYPE RESISTORS.

BAND A		BAND B		BAND C		BAND D		BAND E	
COLOR	FIRST SIGNIFICANT FIGURE	COLOR	SECOND SIGNIFICANT FIGURE	COLOR	MULTIPLIER	COLOR	RESISTANCE TOLERANCE (PERCENT)	COLOR	FAILURE RATE LEVEL
BLACK	0	BLACK	0	BLACK	1	BROWN	±10 (COMP TYPE ONLY)	BROWN	M=1.0
BROWN	1	BROWN	1	BROWN	10	RED	±5	RED	P=0.1
RED	2	RED	2	RED	100	ORANGE	±2 (NOT APPLICABLE TO ESTABLISHED RELIABILITY)	ORANGE	R=0.01
ORANGE	3	ORANGE	3	ORANGE	1,000	YELLOW		YELLOW	S=0.001
YELLOW	4	YELLOW	4	YELLOW	10,000	SILVER		WHITE	
GREEN	5	GREEN	5	GREEN	100,000	GOLD			
BLUE	6	BLUE	6	BLUE	1,000,000	RED			
PURPLE (VIOLET)	7	PURPLE (VIOLET)	7						
GRAY	8	GRAY	8	SILVER	0.01				
WHITE	9	WHITE	9	GOLD	0.1				SOLDERABLE

BAND A — THE FIRST SIGNIFICANT FIGURE OF THE RESISTANCE VALUE (BANDS A THRU D SHALL BE OF EQUAL WIDTH.)  
 BAND B — THE SECOND SIGNIFICANT FIGURE OF THE RESISTANCE VALUE.  
 BAND C — THE MULTIPLIER (THE MULTIPLIER IS THE FACTOR BY WHICH THE TWO SIGNIFICANT FIGURES ARE MULTIPLIED TO YIELD THE NOMINAL RESISTANCE VALUE.)  
 BAND D — THE RESISTANCE TOLERANCE.  
 BAND E — WHEN USED ON COMPOSITION RESISTORS, BAND E INDICATES ESTABLISHED RELIABILITY FAILURE-RATE LEVEL (PERCENT FAILURE PER 1,000 HOURS). ON FILM RESISTORS, THIS BAND SHALL BE APPROXIMATELY 1-1/2 TIMES THE WIDTH OF OTHER BANDS, AND INDICATES TYPE OF TERMINAL.

RESISTANCES IDENTIFIED BY NUMBERS AND LETTERS (THERE ARE NOT COLOR CODED)

SOME RESISTORS ARE IDENTIFIED BY THREE OR FOUR DIGIT ALPHA NUMERIC DESIGNATORS. THE LETTER R IS USED IN PLACE OF A DECIMAL POINT WHEN FRACTIONAL VALUES OF AN OHM ARE EXPRESSED. FOR EXAMPLE:  
 2R7 = 2.7 OHMS 10R0 = 10.0 OHMS

FOR WIRE-WOUND-TYPE RESISTORS COLOR CODING IS NOT USED, IDENTIFICATION MARKING IS SPECIFIED IN EACH OF THE APPLICABLE SPECIFICATIONS.

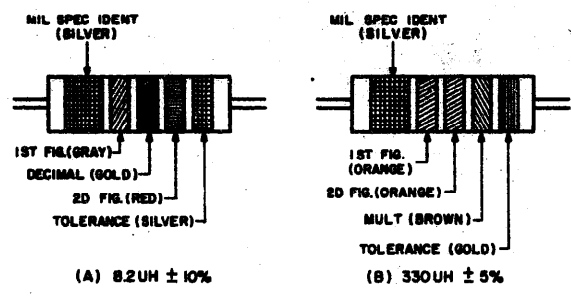

COLOR CODING FOR TUBULAR ENCAPSULATED R.F. CHOKES. AT A, AN EXAMPLE OF THE CODING FOR AN 8.2UH CHOKER IS GIVEN. AT B, THE COLOR BANDS FOR A 330UH INDUCTOR ARE ILLUSTRATED.

TABLE 2  
COLOR CODING FOR TUBULAR ENCAPSULATED R.F. CHOKES.

COLOR	SIGNIFICANT FIGURE	MULTIPLIER	INDUCTANCE TOLERANCE (PERCENT)
BLACK	0	1	
BROWN	1	10	1
RED	2	100	2
ORANGE	3	1,000	3
YELLOW	4		
GREEN	5		
BLUE	6		
VIOLET	7		
GRAY	8		
WHITE	9		
NONE			20
SILVER			10
GOLD		DECIMAL POINT	5

MULTIPLIER IS THE FACTOR BY WHICH THE TWO COLOR FIGURES ARE MULTIPLIED TO OBTAIN THE INDUCTANCE VALUE OF THE CHOKER COIL.

CAPACITORS, FIXED, VARIOUS-DIELECTRICS, STYLES CM, CN, CY, AND CB.

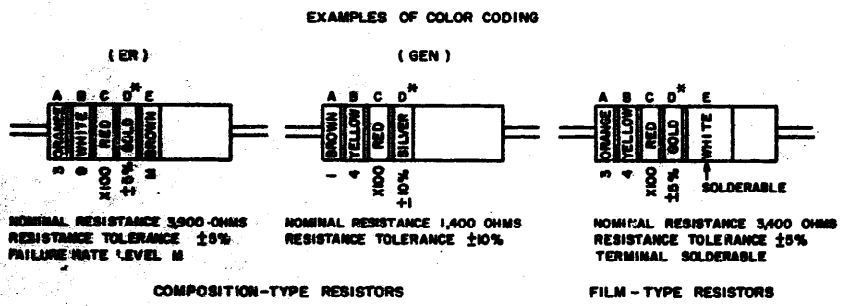
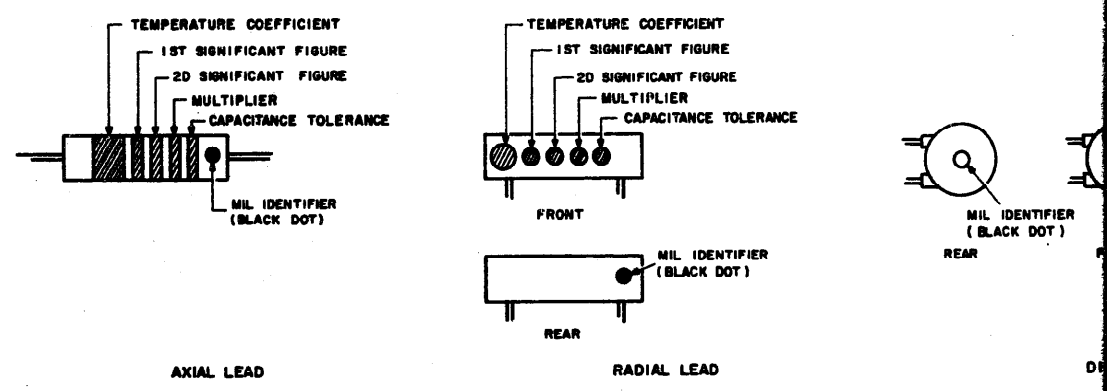
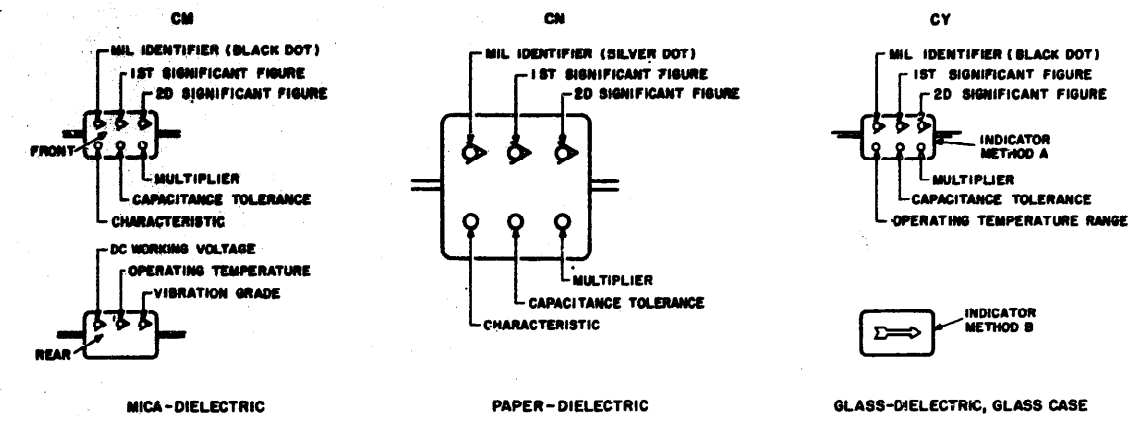

IF BAND D IS OMITTED, THE RESISTOR TOLERANCE IS ±20% AND THE RESISTOR IS NOT MIL-STD.

A. COLOR CODE MARKING FOR MILITARY STANDARD RESISTORS. B. COLOR CODE MARKING FOR MILITARY STANDARD INDUCTORS.

Figure F0-1. Color code markings for MIL-STD resistors, inductors and capacitors.

CAPACITORS, FIXED, VARIOUS-DIELECTRICS, STYLES CM, CN, CY, AND CB.

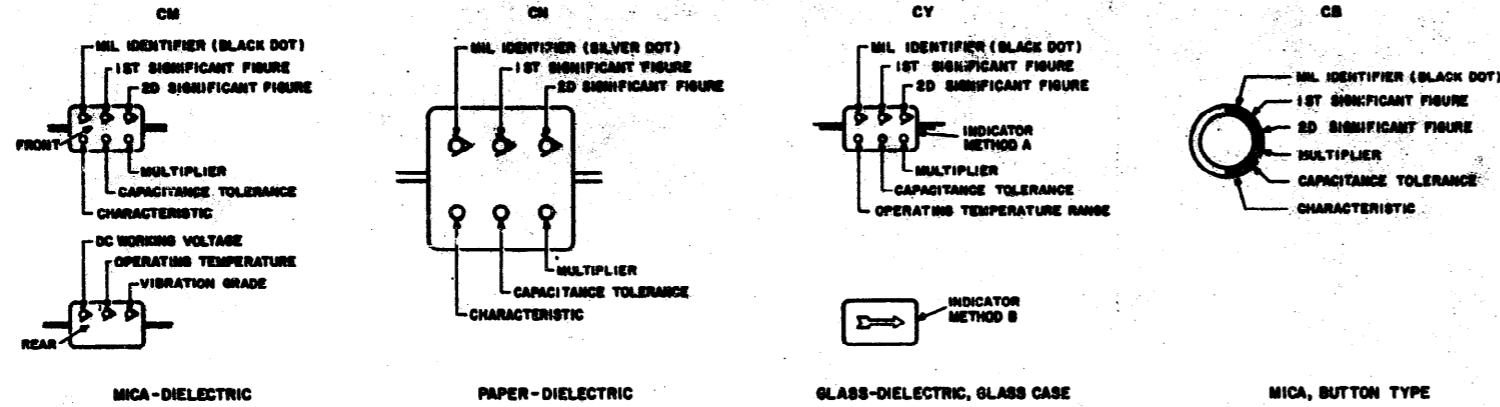

A. AN EXAMPLE OF COLOR BANDS FOR

R.F. CHOKES.



FOR FIGURES OF THE

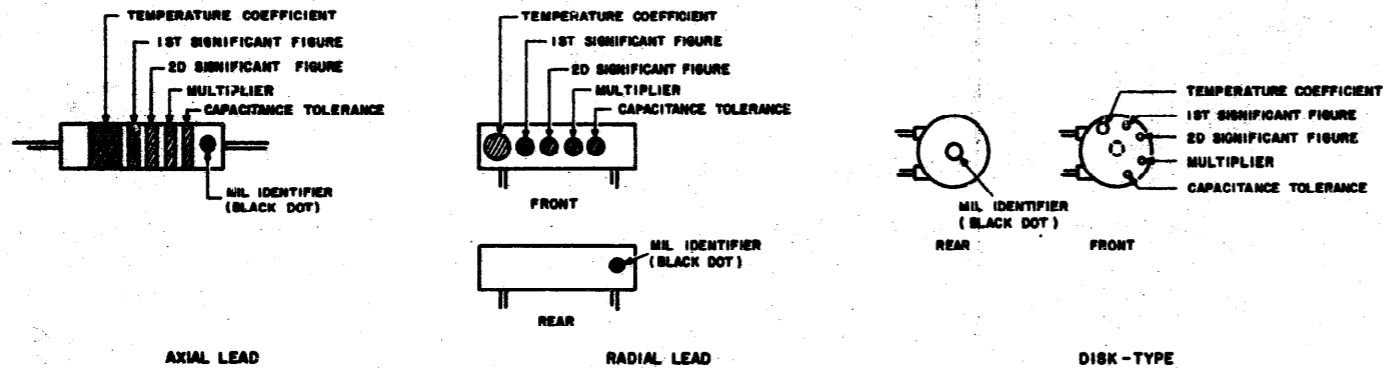

TABLE 3 - FOR USE WITH STYLES CM, CN, CY AND CB.

COLOR	MIL ID	1ST SIG FIG.	2D SIG FIG.	MULTIPLIER <sup>1</sup>	CAPACITANCE TOLERANCE				CHARACTERISTIC <sup>2</sup>			DC WORKING VOLTAGE	OPERATING TEMP RANGE	VIBRATION GRADE
					CM	CN	CY	CB	CM	CN	CB			
BLACK	00	0	0	1			±20%	±20%		A	B		-55° to +70°C	10-55 HZ
BROWN	1	1					±2%						-55° to +85°C	
RED	2	2		100	±2%		±2%	±2%	C				-55° to +85°C	
ORANGE	3	3		1,000	±20%				D	D	300		-55° to +85°C	10-2,000 HZ
YELLOW	4	4							E				-55° to +85°C	
GREEN	5	5			±5%				F		500		-55° to +85°C	
BLUE	6	6											-55° to +85°C	
PURPLE (VIOLET)	7	7											-55° to +85°C	
GRAY	8	8											-55° to +85°C	
WHITE	9	9											-55° to +85°C	
GOLD				0.1	±10%	±10%	±10%	±10%					-55° to +85°C	
SILVER	CN			0.01	±10%	±10%	±10%	±10%					-55° to +85°C	

TABLE 4 - TEMPERATURE COMPENSATING, STYLE CC.

COLOR	TEMPERATURE COEFFICIENT <sup>4</sup>	1ST SIG FIG.	2D SIG FIG.	MULTIPLIER <sup>1</sup>	CAPACITANCE TOLERANCE		MIL ID
					CAPACITANCES OVER 10 UUF	CAPACITANCES 10 UUF OR LESS	
BLACK	0	0	0	1		±2.0 UUF	CC
BROWN	-30	1	1	10	±1%		
RED	-60	2	2	100	±2%	±0.25 UUF	
ORANGE	-150	3	3	1,000			
YELLOW	-220	4	4				
GREEN	-330	5	5		±5%	±0.5 UUF	
BLUE	-470	6	6				
PURPLE (VIOLET)	-750	7	7				
GRAY		8	8	0.01*			
WHITE		9	9	0.1*	±10%		
GOLD	+100			0.1		±1.0 UUF	
SILVER				0.01			

1. THE MULTIPLIER IS THE NUMBER BY WHICH THE TWO SIGNIFICANT (SIG) FIGURES ARE MULTIPLIED TO OBTAIN THE CAPACITANCE IN UUF.
  2. LETTERS INDICATE THE CHARACTERISTICS DESIGNATED IN APPLICABLE SPECIFICATIONS: MIL-C-5, MIL-C-250, MIL-C-11272B, AND MIL-C-10950C RESPECTIVELY.
  3. LETTERS INDICATE THE TEMPERATURE RANGE AND VOLTAGE-TEMPERATURE LIMITS DESIGNATED IN MIL-C-11015D.
  4. TEMPERATURE COEFFICIENT IN PARTS PER MILLION PER DEGREE CENTIGRADE.
- \* OPTIONAL CODING WHERE METALLIC PIGMENTS ARE UNDESIRABLE.

Figure F0-1. Color code markings for MIL-STD resistors, inductors and capacitors.

C. COLOR CODE MARKING FOR MILITARY STANDARD CAPACITORS.

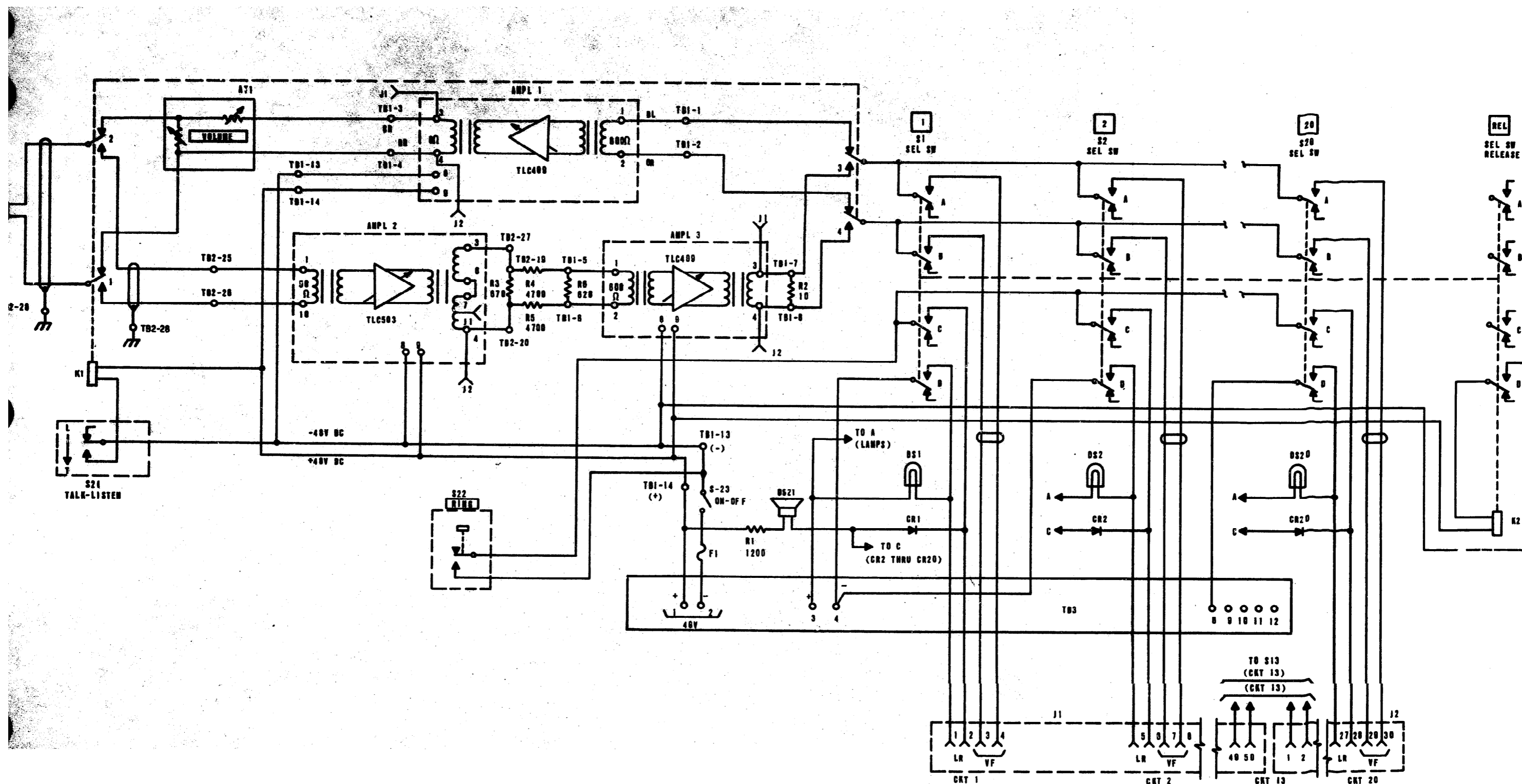

Figure F0-2. Central intercom unit, schematic diagram.



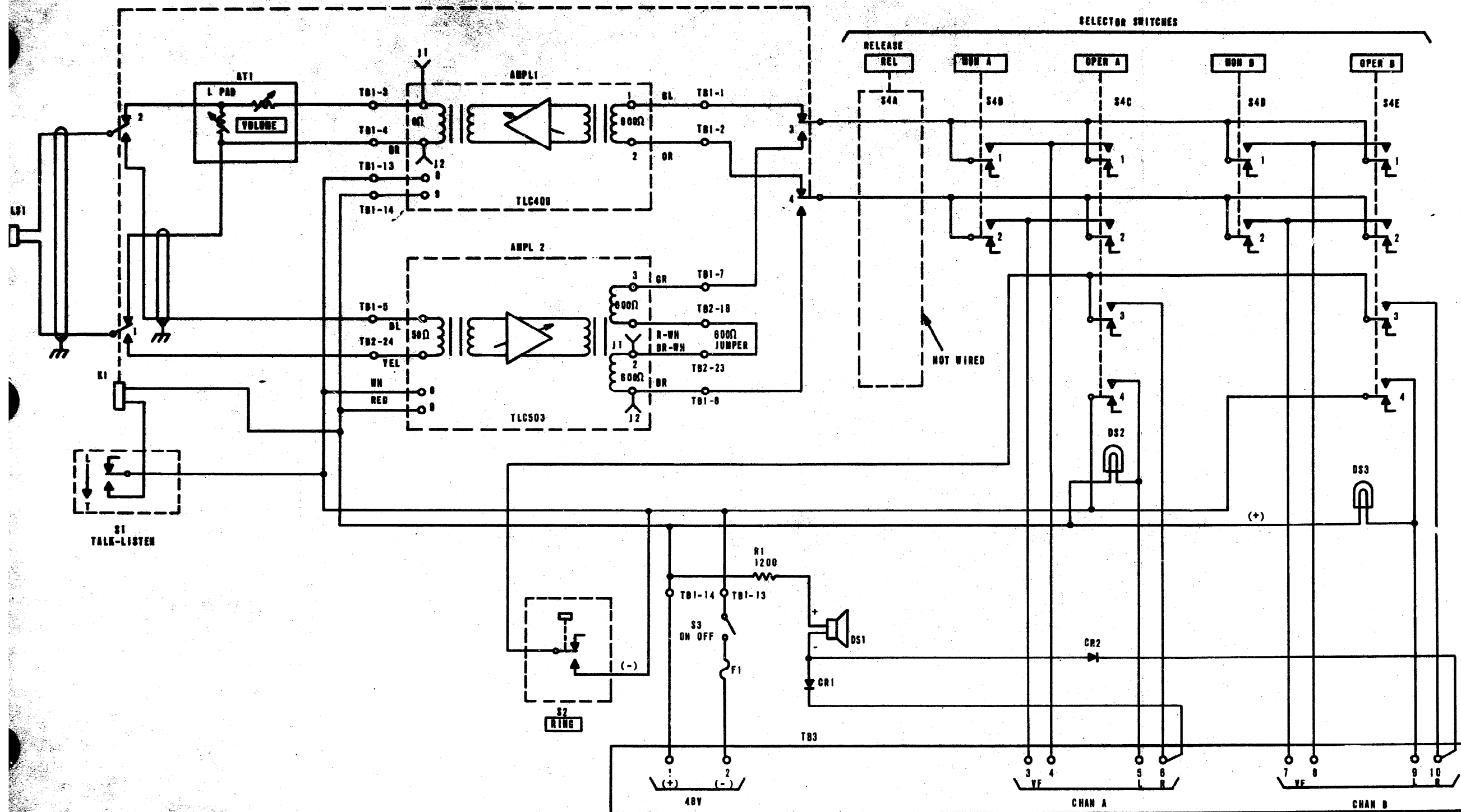

Figure F0-3. Remote intercom unit, schematic diagram.